

Owners Manual

evince™ INSIGHT™



- 1. Page 18 of this manual contains important maintenance procedures for the continued proper operation of your unit. These MUST be performed regularly for your warranty to remain valid.**
- 2. Read all instructions carefully before operation.**
- 3. Avoid pinched o-rings during installation by applying NSF certified lubricant to all seals (provided with install kit).**
- 4. This system is not intended for treating water that is microbiologically unsafe or of unknown quality without adequate disinfection before or after the system.**

Evinco Water Group Inc.®
Direct Phone Number: 951.336.0966
1641 Commerce St.
Corona, CA 92878



Table of Contents

READ THIS PAGE FIRST	5
SPECIFICATIONS	6
WATER AND TIME CONSUMED DURING REGENERATION	7
CONTROL VALVE REGENERATION SEQUENCE	7
UNPACKING / INSPECTION	8
FIND AND RECORD VALVE TYPE & SERIAL NUMBERS / RECORDS & CONTACTS	9
BEFORE INSTALLATION	10
PREPARATIONS	11
INSTALLATION STEPS	12
INSTALLATION	13
STARTUP INSTRUCTIONS	15
DURING REGENERATION	16
PLUMBING SYSTEM CLEAN-UP	17
SYSTEM MAINTENANCE	18
SERVICING EVINCE INSIGHT VALVE	18
DIAGNOSTIC SCREEN	21
REPLACE PISTON AND/OR BRINE VALVE ASSEMBLY	22
CLEAN INJECTOR ASSEMBLY	22
REPLACE TIMER	23
REPLACE MOTOR	23
REPLACING THE BYPASS AND METER CABLE	24
DISPLAY REPLACEMENT	25
REPLACE MICROSWITCHES	25
REPLACE DRAIN LINE FLOW CONTROL	26
REPLACE BRINE LINE FLOW CONTROL	26
AFTER SERVICING	26
PARTS BREAKDOWN	27
TROUBLE SHOOTING GUIDE	30
WARRANTY	32

READ THIS PAGE FIRST

BEFORE STARTING INSTALLATION

- ▶ Read this manual thoroughly to become familiar with the device and its capabilities before installing or operating your Water Conditioner. Failure to follow instructions in this manual could result in personal injury or property damage. This manual will also help you to get the most out of your conditioner.
- ▶ This system is intended for use on municipal water only and its installation must comply with all State, provincial or local regulations. Check with your local public works department for plumbing and sanitation codes. In the event the codes conflict with any content in this manual the local codes should be followed. Consult your licensed plumber for installation of this system.
- ▶ This water conditioner is designed to operate on pressures of 30 psi to 125 psi. If the water pressure is higher than the maximum use a pressure reducing valve in the water supply line to the conditioner.
- ▶ This unit is capable of operating at temperatures between 40°F and 110°F (4°C - 43°C). Do not use this water conditioner on hot water supplies.
- ▶ Do not install this unit where it may be exposed to wet weather, direct sunlight, or temperatures outside of the range specified above.
- ▶ Avoid pinched o-rings during installation by applying (provided with install kit) NSF certified lubricant to all seals.
- ▶ It is not uncommon for sediment, precipitated iron or hardness to be present in water supplies. Precipitated minerals or sediments can cause damage to the seals and piston. This is considered a harsh environment and the seals and piston would not be covered by warranty stated or otherwise.
- ▶ It is recommended to regularly inspect and service the control valve on an annual basis. Cleaning and or replacement of piston, seals, and or spacers may be necessary depending on how harsh the conditions are. An Annual Maintenance kit (Part # 60010565) is available for this purpose
- ▶ Do not use water that is microbiologically unsafe without adequate disinfection before or after this system.
- ▶ This publication is based on information available when approved for printing. Continuing design refinement could cause changes that may not be included in this publication. The manufacturer reserves the right to change the specifications referred to in this literature at any time, without prior notice.

INSTALL NOTES & SAFETY MESSAGES

Watch for the following messages in this manual:

NOTE

Do not remove or destroy the serial number. It must be referenced on request for warranty repair or replacement

NOTE: used to emphasize installation, operation or maintenance information which is important but does not present a hazard.



CAUTION!

Disassembly while under pressure can result in flooding.

CAUTION: used when failure to follow directions could result in damage to equipment or property.



WARNING!

ELECTRICAL SHOCK HAZARD! UNPLUG THE UNIT BEFORE REMOVING THE COVER OR ACCESSING ANY INTERNAL CONTROL PARTS

WARNING: used to indicate a hazard which could cause injury or death if ignored.

SPECIFICATIONS

All units are factory programmed to the below specifications. Alteration should only be done by a factory trained technician or after consultation with one of our technical representatives if you have any questions please contact:

Evince™ Direct Phone Number: 951.734.7400

Evince Filters

Models	Media Cu Ft	Flow Rate USGPM		Mineral Tank Size	Pipe Size Inches	Ship Weight Lbs
		Service	Peak			
EV-IN-BW-948-1.0	1.00	5.0	7.0	9 x 48	3/4" - 1.25"	60
EV-IN-BW-1054-1.0	1.50	7.0	10.0	10 x 54	3/4" - 1.25"	78
EV-IN-BW-1252-1.0	2.00	10.0	12.0	12 x 52	3/4" - 1.25"	95
EV-IN-BW-1354-1.0	2.50	12.0	15.0	13 X 54	3/4" - 1.25"	125

Working Temperature: This unit must be operated at temperatures between 40°F and 110°F (4°C - 43°C).

Working Pressure: This water refiner must be operated on pressures between 30 psi to 125 psi. If the water pressure is higher than 125 PSI, use a pressure reducing valve in the water supply line to the refiner.

Voltage = 120V / 60 Hz
Pipe Size = 3/4", 1" and 1.25"

- At the stated service flow rates, the pressure drop through these devices will not exceed 15 psig.
- The manufacturer reserves the right to make product improvements which may

deviate from the specifications and descriptions stated herein, without obligation to change previously manufactured products or to note the change.

* Do not use water that is microbiologically unsafe without adequate disinfection before or after the system.

Peak flow rates intended for intermittent use only (10 minutes or less) and are for residential applications only. Do not use peak flow rate for commercial applications or for a continuous rate when treated water supplies are geothermal heat pump, swimming pool, etc.

For satisfactory operation, the pumping rate of the well system must equal or exceed indicated backwash flow rate.

All units come with plastic bypass

Note: Evince Systems can be installed into homes and small commercial applications with up to 1.25" plumbing. Optional 1.25" connections available upon request.

SYSTEM DIMENSIONS

Models	A (Inches)	B (Inches)	C (Inches)
EV-IN-BW-948-1.0	58"	9"	13"
EV-IN-BW-1054-1.0	64"	10"	13"
EV-IN-BW-1252-1.0	62"	12"	13"
EV-IN-BW-1354-1.0	64"	12"	13"

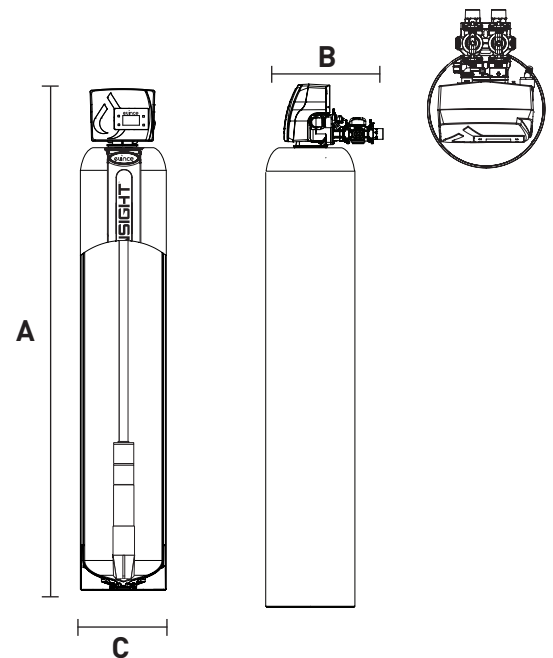

WATER AND TIME CONSUMED DURING REGENERATION

Models	Backwash Minutes	Rapid Rinse Minutes	Total Time of Regeneration	Total Water Consumed during Regeneration (GAL)
150	10	10	20	100

V-ELA-TT-

CONTROL VALVE REGENERATION SEQUENCE

The regeneration cycle goes through 3 steps.

- 1. Backwash (minimum 30 psi inlet pressure required):** During the backwash cycle, water flows upwards through the bed, expanding the media and carrying any contaminants trapped within it to the drain.
- 2. Rapid Rinse:** During the rapid rinse cycle, water flows downwards through the bed, settling the media and carrying any precipitated contaminants trapped within it to the drain.
- 3. In-Service Position:** The unit then returns to the In-Service position. While this happens water continues to enter the tank.

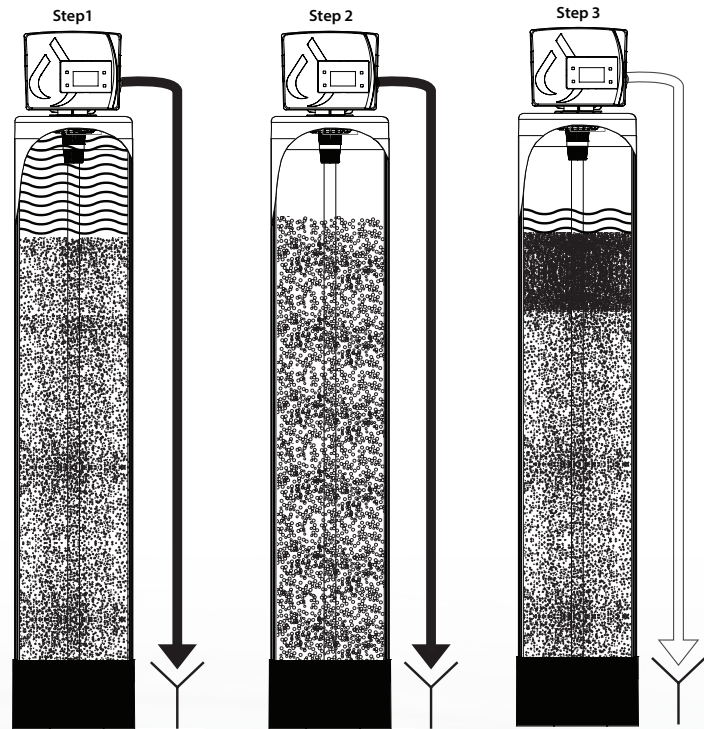

UNPACKING / INSPECTION

Be sure to check the entire unit for any shipping damage or parts loss. Also note damage to the shipping cartons. Contact the transportation company for all damage and loss claims. **The manufacturer is not responsible for damages in transit.**

Small parts, needed to install the Conditioner, are in a parts box. To avoid loss of the small parts, keep them in the parts bag until you are ready to use them.

Models: EV-IN-BW-948-1.0, EV-IN-BW-1054-1.0, EV-IN-BW-1252-1.0, EV-IN-BW-1354-1.0

What is included in the box?

1. Control Valve
2. Pressure Tank
3. Parts Box
4. Owners Manual
5. Drain Hose & Clamp

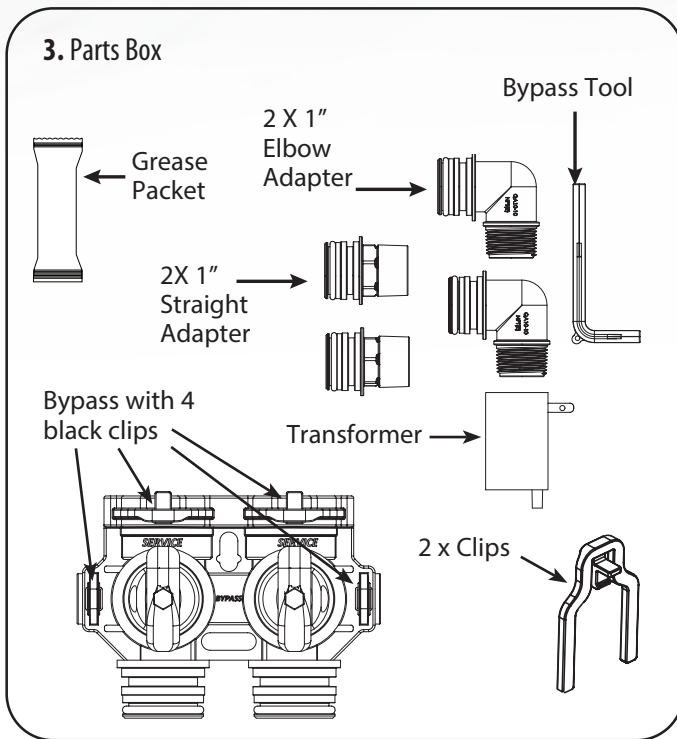
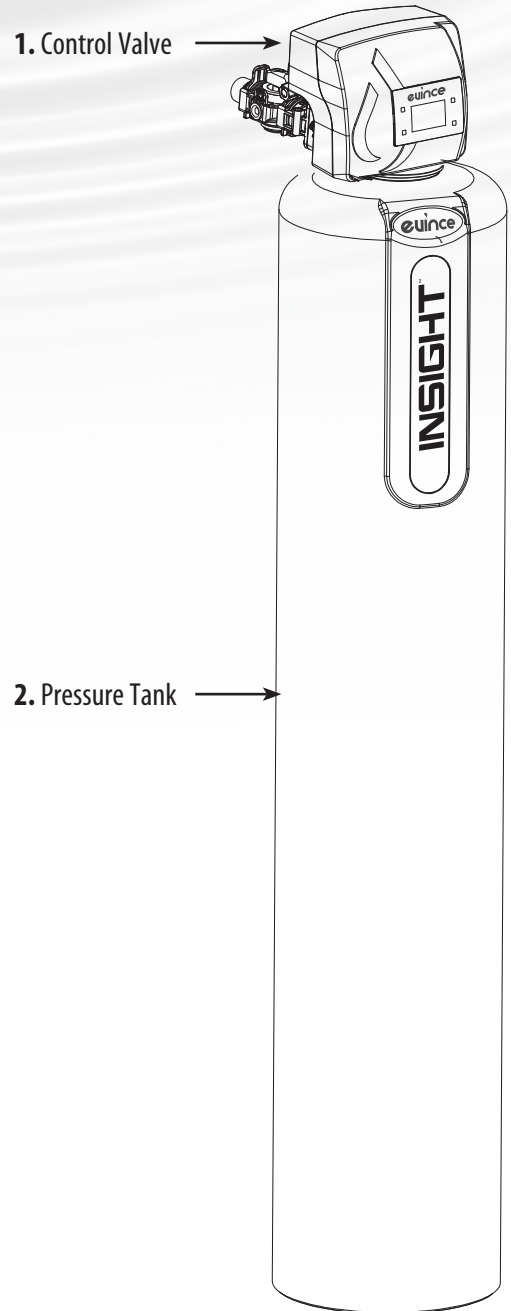

FIND AND RECORD VALVE TYPE & SERIAL NUMBERS

There are two labels located on your Unit: **1)** Control valve label and **2)** System number label. Find and record your product model number, serial number, and valve serial number in the **Records & Contacts** section as they will be important if you need to troubleshoot.



Control Valve Serial #

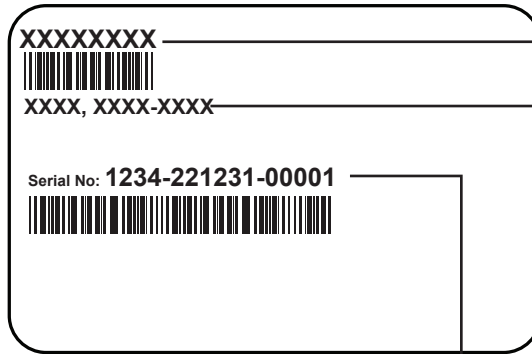

System Serial #

Item #

Model #

RECORDS & CONTACTS

Please have the information below filled out and available when calling in for parts or warranty:

Model number:
Serial number:
Valve Serial number:
Date installed:

Additional notes:

BEFORE INSTALLATION

Make sure you have a copy of your most recent water test results. If your water has not been tested previously you can contact your supplier of this product to obtain a water sample bottle to be sent to one of our facilities for a free analysis. **It is important that this product not be installed until you have this information.**

In all cases where metal pipe was originally used and is later interrupted by poly pipe or the Noryl bypass valve or by physical separation, an approved ground clamp with no less than #6 copper conductor must be used for continuity, to maintain proper metallic pipe bonding.

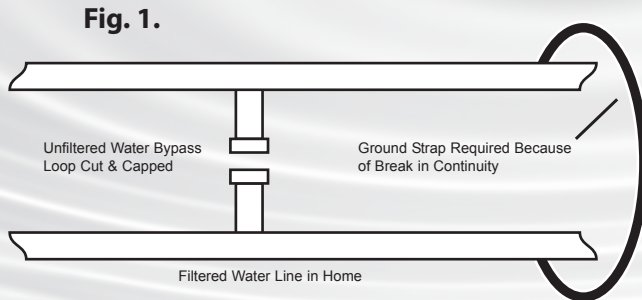

Inspecting and Handling Your EV-IN-BW Conditioner*

Inspect the equipment for any shipping damage. If damaged, notify the transportation company and request a damage inspection. Damage to cartons should also be noted.

Handle the conditioner unit with care. Damage can result if it is dropped or set on sharp, uneven projections on the floor.

Do not turn the conditioner unit upside down.

To Ensure this Product Functions Properly:

Your feed water line size to the unit must be a minimum of 1/2 inch with an operating pressure of no less than 30 psi and no more than 125 psi.

MECHANICAL:

Do not use petroleum based lubricants such as petroleum jelly, oils or hydrocarbon based lubricants. Use only 100% silicone lubricants (grease packet provided in parts kit). All plastic connections should be hand tightened only. Teflon tape may be used on connections that do not use an O-ring seal. Do not use pliers or pipe wrenches except where indicated by Nut shape (eg. pipe adapters) All plumbing must be completed according to local codes. Soldering connections should be done before connecting any pieces to the pipe as excessive heat can damage them.

Tools Required for Installation:

NOTE: We recommend installation only be completed by a competent installer or plumbing professional to insure this product is installed in accordance with local plumbing codes.

- ▶ Two adjustable wrenches
- ▶ Additional tools may be required if modification to home plumbing is required.
- ▶ Plastic inlet and outlet fittings are included with the conditioner. To maintain full valve flow, 3/4" or 1" pipes to and from the conditioner fittings are recommended. You should maintain the same, or larger, pipe size as the water supply pipe, up to the conditioner inlet and outlet.
- ▶ Use copper, brass, or PEX pipe and fittings.
- ▶ Some codes may also allow PVC plastic pipe.
- ▶ ALWAYS install the included bypass valve, or 3 shut-off valves. Bypass valves let you turn off water to the conditioner for repairs if needed, but still have water in the house pipes.
- ▶ 5/8" OD drain line is needed for the valve drain. A 10' length of hose is not included with some models.

NOTE

All government codes and regulations governing the installation of these devices must be observed.



CAUTION!

If the ground from the electrical panel or breaker box to the water meter or underground copper pipe is tied to the copper water lines and these lines are cut during installation of the Noryl bypass valve and/or poly pipe, an approved grounding strap must be used between the two lines that have been cut in order to maintain continuity. The length of the grounding strap will depend upon the number of units being installed and/or the amount of copper pipe being replaced with plastic pipe.

See Fig. 1.

NOTE

Check your local electrical code for the correct clamp and cable size.

NOTE

If a severe loss in water pressure is observed when the conditioner unit is initially placed in service, the conditioner tank may have been laid on its side during transit. If this occurs, backwash the conditioner to "reclassify" the media.

*NOTE

Due to transportation and climatic conditions all connections including the valve to the tank need to be checked at time of installation and tightened if necessary.

PREPARATIONS

- Media Installation (When Necessary).** Models larger than 2.0 CF of media are shipped with separate media in pails or boxes. Models lower than 1.5 CF of media come loaded with media and this step can be skipped for new installation.



CAUTION!

The unit should be depressurized before installing or replacing media

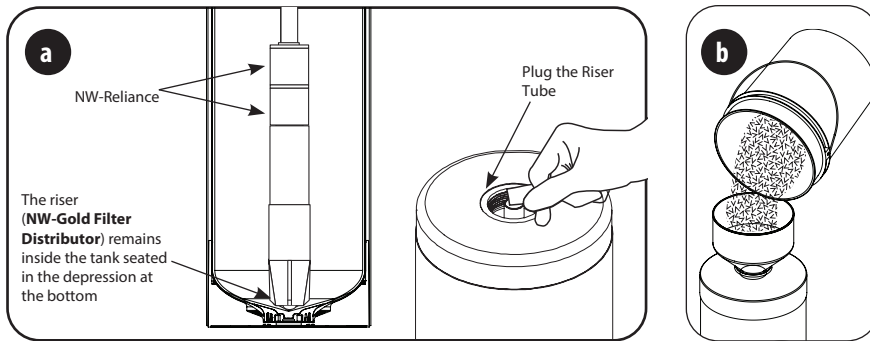

- Temporarily plug the open end of the riser tube to ensure that no resin or gravel falls down into the distribution. The riser (distributor) remains inside the tank seated in the depression at the bottom.

Plug tube with a tape. Remove after media is loaded.

- Fill support bed first. The media will not always spill down inside the tank and may need to be swept inside.

The large funnel (sold separately makes filling the tank easier and neater. (Or an empty 1 gallon or 4 liter container with the bottom cut out makes a good funnel.)

Locate Water Conditioning Equipment Correctly

Select the location of your filter tank with care. Various conditions which contribute to proper location are as follows:

- Locate as close as possible to the water supply source.
- Locate as close as possible to a floor or laundry tub drain.
- Locate in correct relationship to other water conditioning equipment. if closer than 10 feet please install check valve in accordance with local plumbing codes.
- Conditioners should be located in the supply line before the water heater. Temperatures above 110°F (43°C) will cause damage to conditioners.
- Do not install a filter or filter in a location where freezing temperatures occur. Freezing may cause permanent damage to this type of equipment and will void the factory warranty.
- Allow sufficient space around the unit for easy servicing.
- Keep the filter out of direct sunlight. The sun's heat may soften and distort plastic parts.

NOTE

Never make a direct connection into a waste drain. A physical air gap of at least 1.5" should be used to avoid bacteria and wastewater travelling back through the drain line into the softener.

NOTE

The unit is not ready for service until you complete the start-up instructions, page 15.

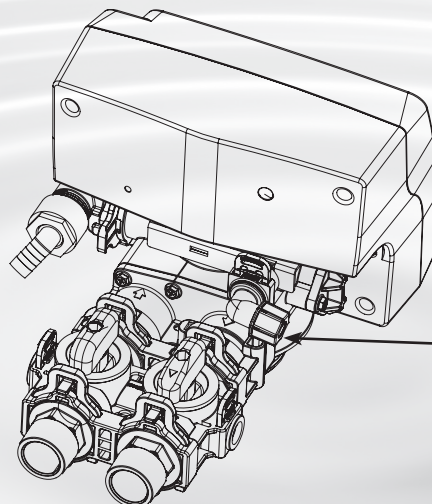

Make sure both brass and plastic nuts are tightened well

INSTALLATION STEPS

1. Determine the best location for your water filter, bearing in mind the location of your water supply lines, drain line and 120 volt AC electrical outlet. Subjecting the filter to freezing or temperatures above 43°C (110°F) will void the warranty.

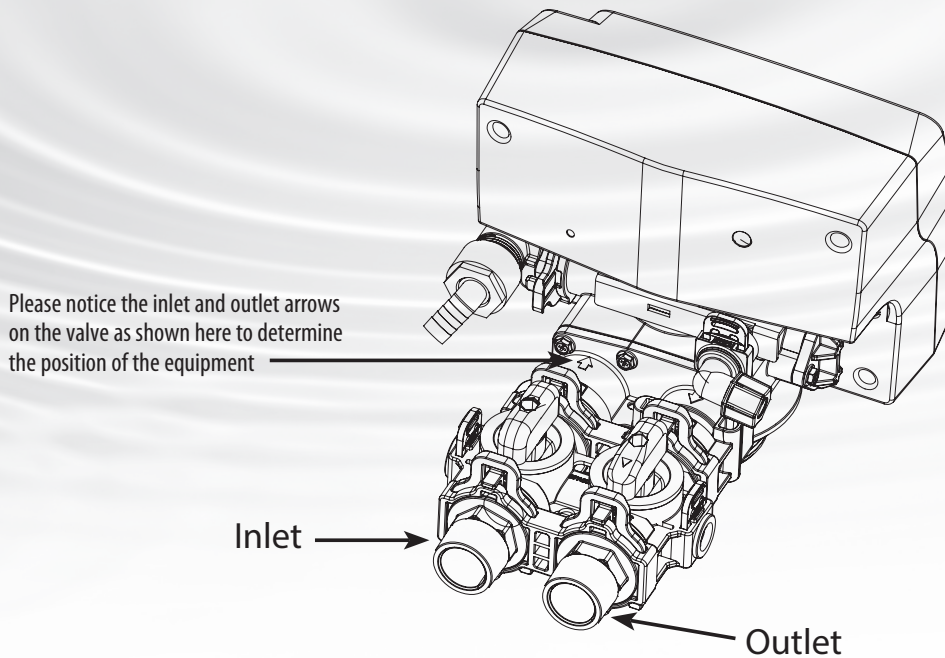

Facts to Remember When Planning Your Installation

1. All installation procedures must conform to local and state or provincial plumbing codes.
2. Outside faucets used to water lawns and gardens should not supply untreated water, replace untreated water with feed water to the unit. If necessary to do this please install check valve, see page 14. A new water line is often required to be connected to supply untreated water to the inlet of the water filter and to the outside faucets.
3. Make sure the bypass is attached well to the control valve. Connect the straight or elbow connectors to the bypass with red clips. Connect the inlet and outlet of the water filter to the plumbing of the house. The control valve must not be submitted to temperatures above 43°C (110°F). When sweat fittings are used, to avoid damaging the control valve, solder the threaded copper adapters to the copper pipe and then, using Teflon tape, screw the assembly into the bypass valve.
Do not use pipe thread compound as it may attack the material in the valve body.
4. Apply Teflon Tape and Orings to the fittings
5. Connect Filter to the house plumbing. Any solder joints near the valve must be done before connecting any piping to the valve. Always leave at least 6" (152 mm) between the valve and joints when soldering pipes that are connected to the valve. Failure to do this could cause damage to the valve.
6. **Drain Line connection:** Using Teflon tape, screw the 1/2" hose barb and attach oring into the drain port in the valve. Attach 1/2" drain hose (Supplied with some models and brands) to the hose barb and tighten securely with a hose clamp (Supplied with some models and brands). Run the drain line to a floor drain or a laundry drain. Complete any necessary plumbing.
7. Using the Allen Key (included), place the unit in the bypass position. Slowly turn on the main water supply. At the nearest cold treated water tap nearby remove the faucet screen, open the faucet and let water run a few minutes or until the system is free of any air or foreign material resulting from the plumbing work.
8. Make sure there are no leaks in the plumbing system before proceeding. Close the water tap when water runs clean.
9. Open the brine tank / cabinet salt lid and add water until there is approximately 3" (75 mm) of water in the tank. Do not add salt to the brine tank at this time.

NOTE

If the plumbing system is used as the ground leg of the electric supply, continuity should be maintained by installing ground straps around any nonconductive plastic piping used in installation.

NOTE

Before starting installation, read page 16, Plumbing System Clean-Up, for instructions on some procedures that may need to be performed first.

INSTALLATION

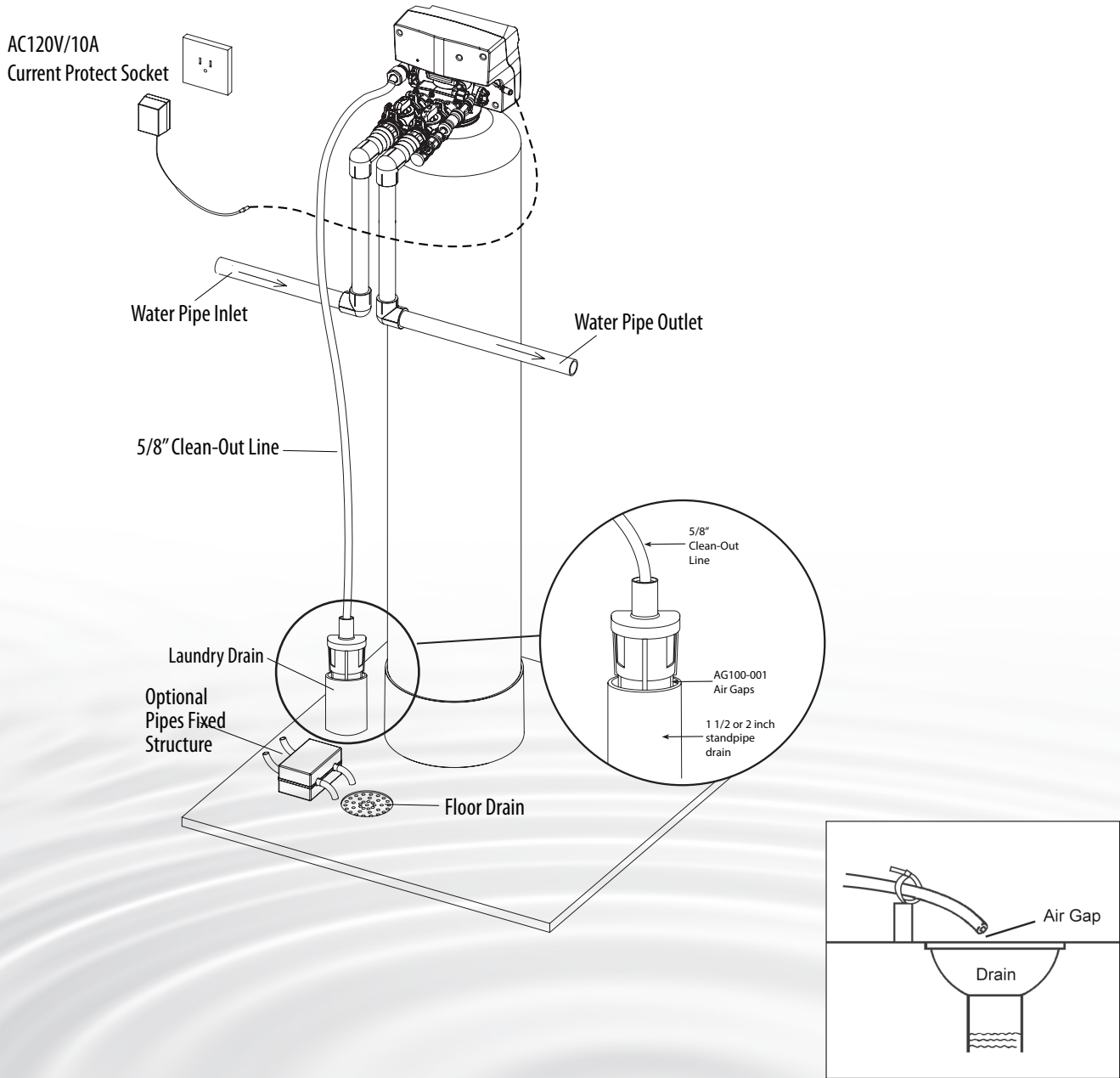
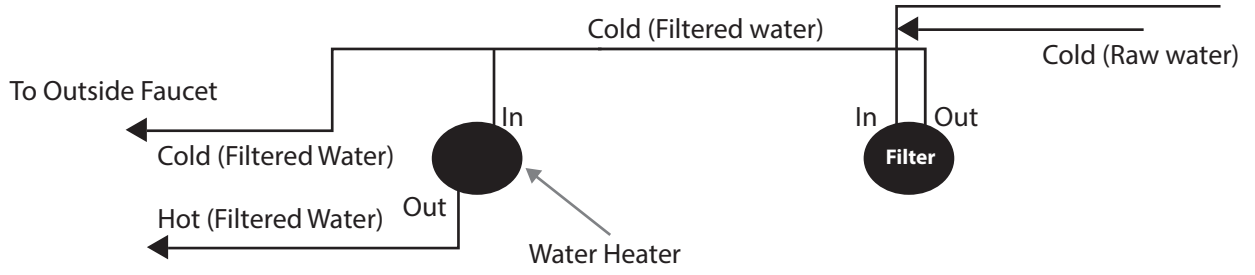

INSTALLATION (CONTINUED)

Evince INSIGHT Units

Open the inlet on the bypass valve slightly and very slowly allow water to enter the unit. (If the water enters too quickly it will push the media up into the control valve and get plugged).

Once the unit has filled sufficiently that water is at least equal to the height of the top of the media shut down the water for 15 – 20 minutes for the media to soak. Unplug the power cable. After the media has soaked for the recommended time continue by plugging the power cable back in.

1. (Other Models) Open the inlet on the bypass valve slowly and allow water to enter the unit. (The outlet of the bypass should remain closed to prevent any fines or debris from entering the plumbing system. Allow all air to escape from the unit before turning the water on fully then allow water to run to drain for 3-4 minutes.
2. Unplug the power cord from the power supply, open inlet. Check the drain line flow. Allow the water to run for 30 minutes.
3. Plug in the valve and the valve will automatically advance to the SERVICE position. Open the outlet valve on the bypass, then slowly open the nearest treated water faucet and allow the water to run until clear, close the tap and replace the faucet screen.
4. The valve is already programmed from the factory. Please set up date and time of day as shown on next page.

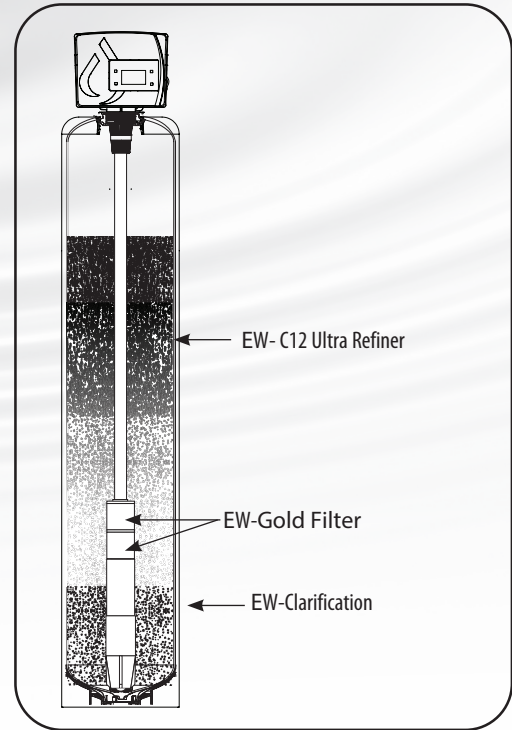

5. Connect Drain Line:

- a) Using plumbers tape, screw the 1/2" hose barb and attach o-ring into the drain port in the valve.
- b) Attach 1/2" drain hose to the hose barb. and tighten securely with a hose clamp.
- c) Run the drain line to a floor drain or a laundry drain. Complete any necessary plumbing.

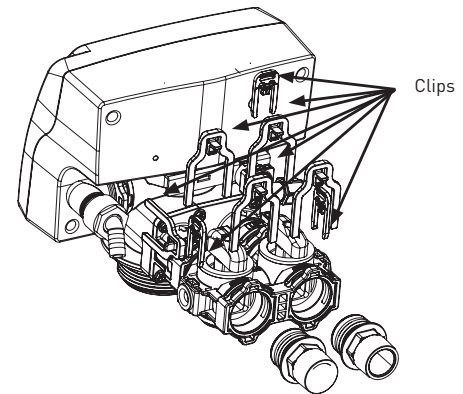
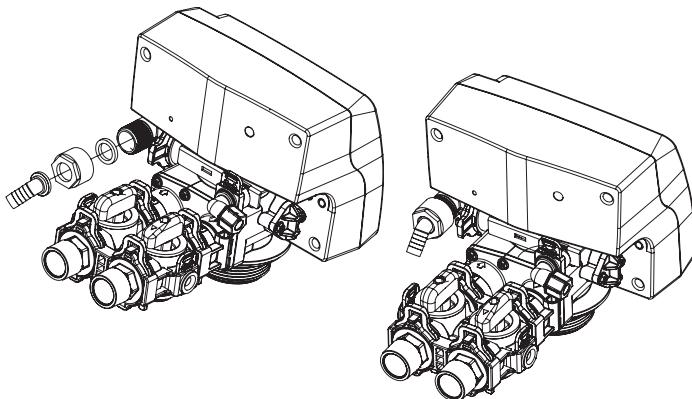

NOTE

DO NOT use petroleum based lubricants. Use only NSF61 food grade lubricants. Petroleum based lubricants will cause swelling of O-ring seals.

CAUTION



WEAR DUST MASK

STARTUP INSTRUCTIONS

1. Connect the Transformer to the Valve

Plug the 12-volt transformer into a 120 VAC 60 Hz outlet.

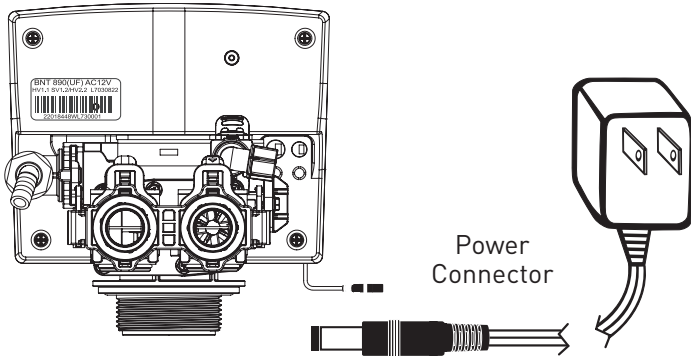

2. Screen Display

When power is supplied to the control, the screen will display "INITIALIZING WAIT PLEASE" while it finds the service position.

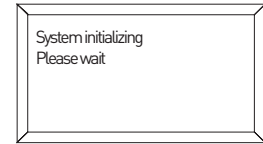

Familiarize with Button Configuration:

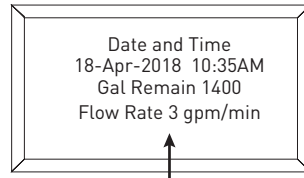
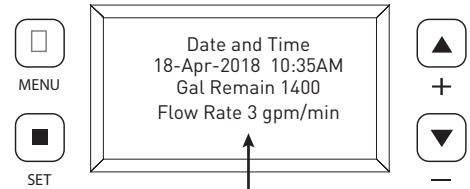

The controller will show the following on the screen: Time, Date and Gallons Remaining for Regeneration

Key Pad Configuration

- MENU This function enters the basic set up information required at the time of installation.
- SET This function accepts the values if changed and advance to the next page in the menu
- These buttons increase or decrease the value of the settings while in the programming mode.

3. Set Up Current Time of Day and Regeneration Time When Filter Should Regenerate When No one uses Water in House.

Press **MENU** Key and Select "**Date and Time**" using **SET** button and set For setting the regeneration time, Press **MENU** Key and Select **Main Menu** till you hear a beep and select **Regen time**.

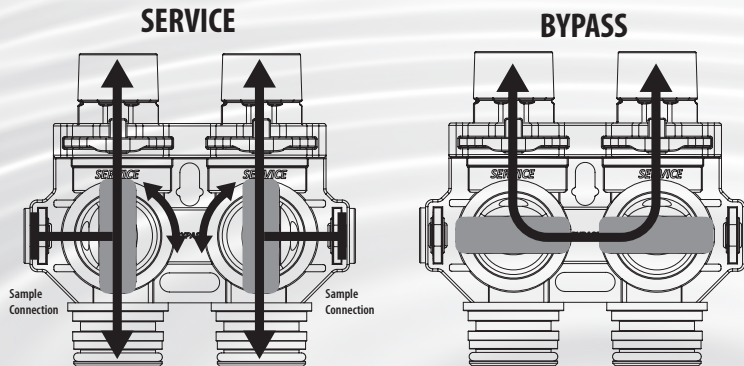

**MANUAL REGEN
DELAY IMMEDIATE**

**BACKWASH
RINSE (SKIP)**

BACKWASH
■■■■■■■■■■■■■■■■■■■■ 10
MINUTES

RINSE
■■■■■■■■■■■■■■■■■■■■ 10 MINUTES

STARTUP INSTRUCTIONS (CONTINUED)

4. set up date and time of day

The Valve is already programmed from factory for refiner models.

Set Up Current Time of Day and Regeneration Time When Refiner Should Regenerate When No one uses Water in House. Press Menu Key and Select "Date and Time" using "Set" Button and set for setting the regeneration time, Press Menu Key and Select Main Menu till you hear a beep and select Regen time.

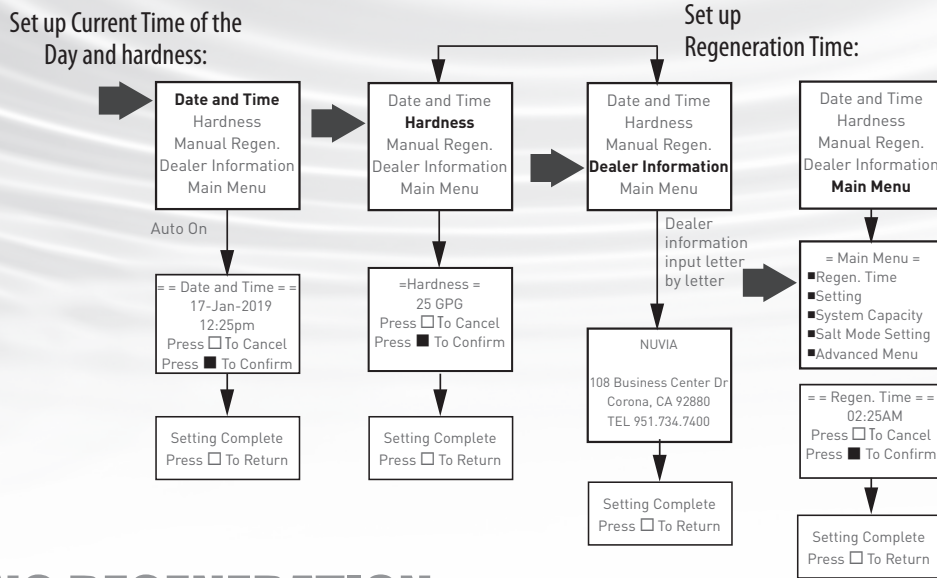

DURING REGENERATION

Automatic Water Bypass

The regeneration cycle can last 20 mins minutes after which filtered water service will be restored. During regeneration, unfiltered water is automatically bypassed for use in the household. Hot water should be used as little as possible during this time to prevent unfiltered water from filling the water heater. This is why automatic regeneration is set for sometime during the night and manual regenerations should be performed when little or no water will be used in the household.

Manual Water Bypass

In the case of emergency you can isolate your water refiner from the water supply using the bypass valve located at the back of the control. In normal operation the bypass is open with the on/off knobs in line with the inlet and outlet pipes.

To isolate the refiner, simply rotate the knobs clockwise (as indicated by the word BYPASS and arrow) until they lock. You can use your water related fixtures and appliances as the water supply is bypassing the refiner. However, the water you use will be untreated.

To resume water service, open bypass valve by rotating the knobs counterclockwise. Please make sure bypass knobs are completely open otherwise the unfiltered water could bypass through the valve.

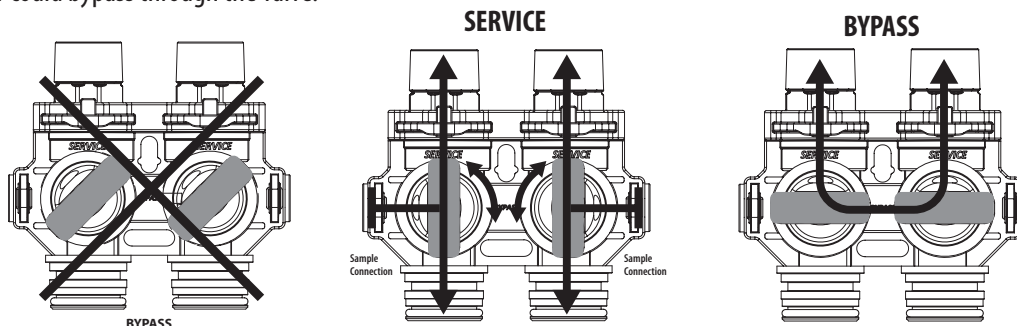

DURING REGENERATION (CONTINUED)

New Sounds

You may notice new sounds as your water conditioner operates. The regeneration cycle lasts approximately 1.5 hours to 3.0 hours depending on the specific model. During this time, you will be able to hear water running intermittently to the drain, depending on proximity of the unit to sleeping area and time of regeneration.

PLUMBING SYSTEM CLEAN-UP

The following procedures are guidelines only but have proven successful in most instances. Under no circumstances should any procedure outlined below be followed if contrary to the appliance manufacturer's instructions. Should there be any questions concerning the advisability of performing a procedure, it is strongly recommended the manufacturer's authorized service outlet be consulted prior to performing the procedure.

Water Heater

If the water heater has been exposed to both iron and hardness for a long period of time, replacement of the heater tank may be the only practical solution to prevent continued staining originating from this source. After completing the installation of the conditioner, clean the water heater by following these instructions:

1. Shut off energy supply to water heater and close heater inlet water valve.
2. Drain hot water tank completely. Open inlet water valve allowing heater tank to be refilled with iron-free water. Continue flushing until water runs clear to drain.
3. If, after approximately 30 minutes flushing, water does NOT clear, terminate flushing operation. Refill hot water heater with water and pour approximately 1/2 gallon of household bleach into top of heater tank. Allow bleach solution to stand in tank for 20 to 30 minutes. Flush tank

NOTE

If water does not clear in approximately 10 minutes, water heater should probably be replaced.

Dishwasher

Consult owners' handbook and follow manufacturer's instructions.

Toilet Flush Tanks

Prior to commencing installation of the conditioner system, pour 4 to 6 ounces of resin mineral cleaner Pro-Rust Out or other suitable cleaner such as CLR that contains a mild acid into flush tanks and bowls and let stand. When installation is completed, flush toilets several times with conditioned water. If stains or deposits return check that lines are connected to treated water. Repeat procedure until clear. again until water is clear at drain. Turn energy supply on.

SYSTEM MAINTENANCE



Maintenance of your new water filter requires very little time or effort but is essential. Regular maintenance will ensure many years of efficient and trouble-free operation. Check with your local dealer about setting up a regular maintenance plan. Failure to follow maintenance instructions and schedule will result in the unit failing to operate properly and void your warranty.

CARE OF YOUR SOFTENER

To retain the attractive appearance of your new water filter, occasionally clean it with a mild soap solution. Do NOT use abrasive cleaners, ammonia, or solvents.

SERVICE SCHEDULE

- The seals and spacers along with the piston assembly should be inspected/cleaned or replaced annually or as required depending on the inlet water quality and water usage. See **Inspection and Replacement of Piston Assembly and Seal and Spacer Kit**.
- The injectors should be cleaned/inspected or replaced annually or as required depending on the water quality and use. See **Clean Injector Assembly**.
- Your inlet water quality and water consumption will determine how often the media should be replenished or replaced. Check with your water treatment expert for the media bed change frequency.

SERVICING EVINCE INSIGHT VALVE

Before Servicing

1. Turn off water supply to conditioner :
 - a. If the conditioner installation has a 3 valve bypass system first open the valve in the bypass line, then close the valves at the conditioner inlet & outlet.
 - b. If the conditioner has an integral bypass valve, put it in the bypass position.
 - c. If there is only a shut-off valve near the conditioner inlet, close it.
2. Relieve water pressure in the conditioner by stepping the control into the backwash position momentarily. Return the control to the In Service position.
3. Unplug Electrical Cord from outlet.
4. Disconnect drain line connection.

WARNING!
ELECTRICAL SHOCK
HAZARD! UNPLUG THE UNIT
BEFORE REMOVING THE
COVER OR ACCESSING ANY
INTERNAL CONTROL PARTS

CAUTION!
Disassembly while under
pressure can result in flooding.
Always follow these steps prior
to servicing the valve.

MASTER PROGRAMMING

Below is how the settings are set at factory:

MODELS	PRESS '+' AND '-' FOR 8 SECONDS						PRESS MENU KEY AND SCROLL TO 'MAIN MENU'. THEN PRESS 'SET' TILL IT BEEPS					VALVE SETTINGS				
	LANGUAGE	REGION	VALVE	METER RATIO	SALT VS EFFICIENCY	AUTO CALCULATION	REGEN. MODE	BACK WASH DURATION	RINSE DURATION	REGEN TIME SETTING	REGEN DAY SETTING	Injec-tor	Injector Color	BLFC Washer	DLFC Washer	DLFC Washer Code
EV-IN-BW-948-1.0	ENGLISH	US GALLONS	FILTER	1.364	DONT TOUCH	OFF	DAYS	10	10	12:00AM	7 DAYS	#1	White	0	5.0	4S
EV-IN-BW-1054-1.0	ENGLISH	US GALLONS	FILTER	1.364	DONT TOUCH	OFF	DAYS	10	10	12:00AM	7 DAYS	#1	White	0	10.0	2
EV-IN-BW-1252-1.0	ENGLISH	US GALLONS	FILTER	1.364	DONT TOUCH	OFF	DAYS	10	10	12:00AM	7 DAYS	#1	White	0	5.0	4S
EV-IN-BW-1354-1.0	ENGLISH	US GALLONS	FILTER	1.364	DONT TOUCH	OFF	DAYS	10	10	12:00AM	7 DAYS	#1	White	0	5.0	4S

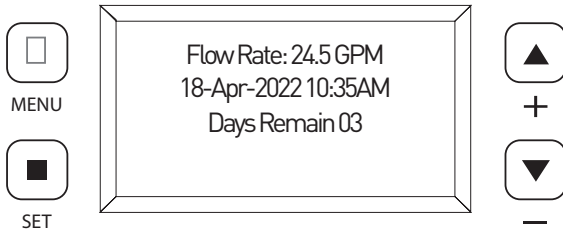

Key Pad Configuration:

- MENU** - This function is to enter the basic set up information required at the time of installation.
- SET/REGEN** - This function is to accept the values if changed and advance to the next page in the menu.
- UP/DOWN** - These buttons are used to increase or decrease the value of the settings while in the programming mode.

MASTER PROGRAMMING

Step A - Region Setting

Press + and —. Hold until you hear a beep (8 seconds).
 Press + or — to choose menu option. Press SETTINGS to enter.
 Press + or — to change option. Press SETTINGS to accept.

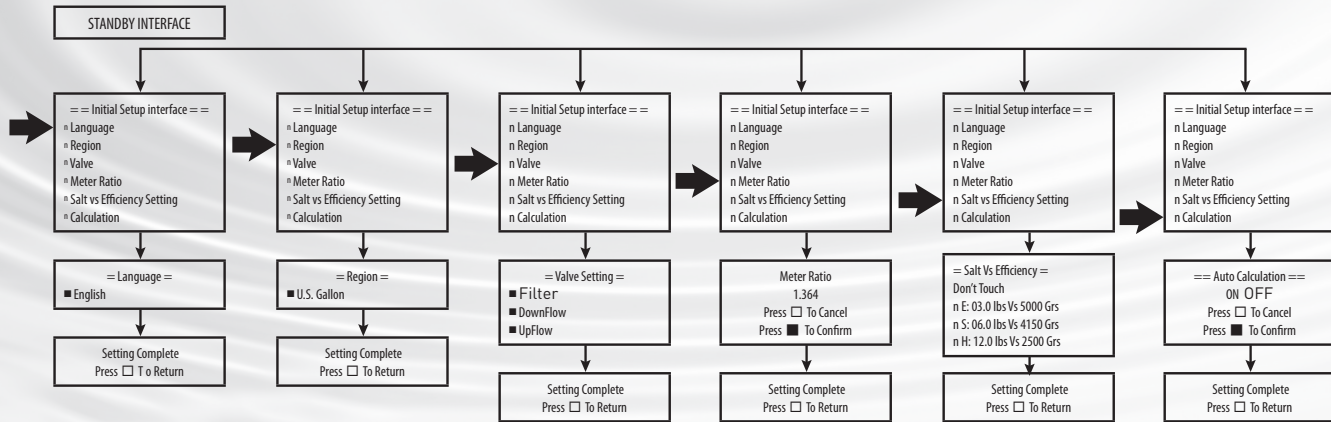

Step B - Advanced Menu

Press Menu key. Press — to advance to Advanced Menu
 Press + or — to choose menu option. Press SET to enter
 Press + or — to change option. Press SET to accept

Press Menu key. Press — to advance to Main Menu
 Press SET or until you hear a beep.
 Press — to advance to Advanced Menu
 Press and hold SET 5 seconds or until you hear a beep.
 Press + or — to choose menu option. Press SET to enter.
 Press + or — to change option. Press SET to accept.

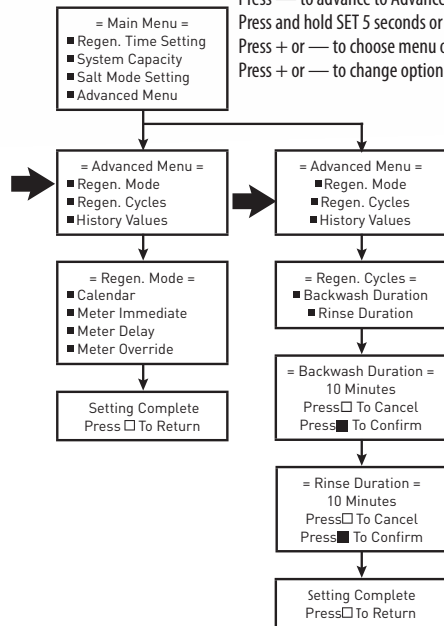

Step C - Main Menu

Press Menu key. Press — to advance to Advanced Menu
 Press SET or until you hear a beep
 Press + or — to choose menu option. Press SET to enter
 Press + or — to change option. Press SET to accept

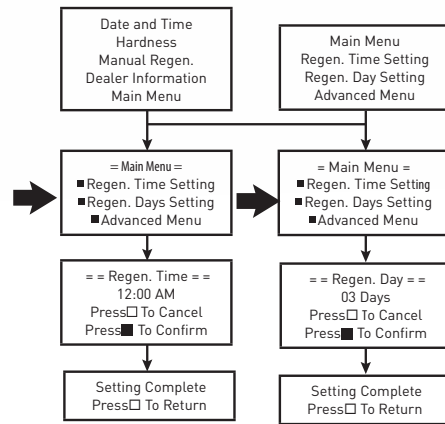

Step D - User Setting

Press Menu key
 Press SET or until you hear a beep
 Press + or — to choose menu option. Press SET to enter
 Press + or — to change value. Press SET to accept

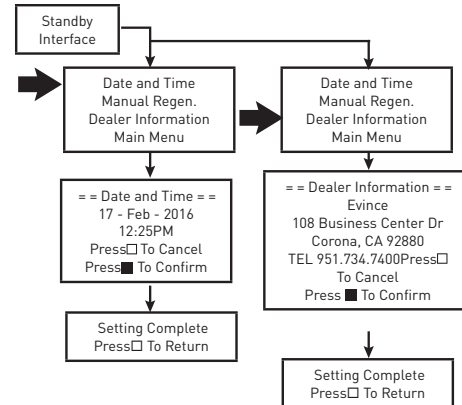

DIAGNOSTIC SCREEN

PRESS "MENU" KEY AND SCROLL TO "MAIN MENU". THEN PRESS "SET" TILL IT BEEPS. SCROLL TO ADVANCED MENU

PRESS "MENU" KEY AND SCROLL TO "MAIN MENU". THEN PRESS "SET" TILL IT BEEPS. SCROLL TO ADVANCED MENU, Press and hold "SET" 5 seconds or until you hear a beep.

Press "Menu" key . Press - to advance to Main Menu. Press "SET" or until you hear a beep. Press - to advance to Advanced Menu Press and hold "SET" 5 seconds or until you hear a beep. Press - to advance to History Values. Press "SET" or until you hear a beep. Press "+" or "-" to choose menu option. Press "SET" to enter. Press "+" or "-" to change option. Press "SET" to accept.

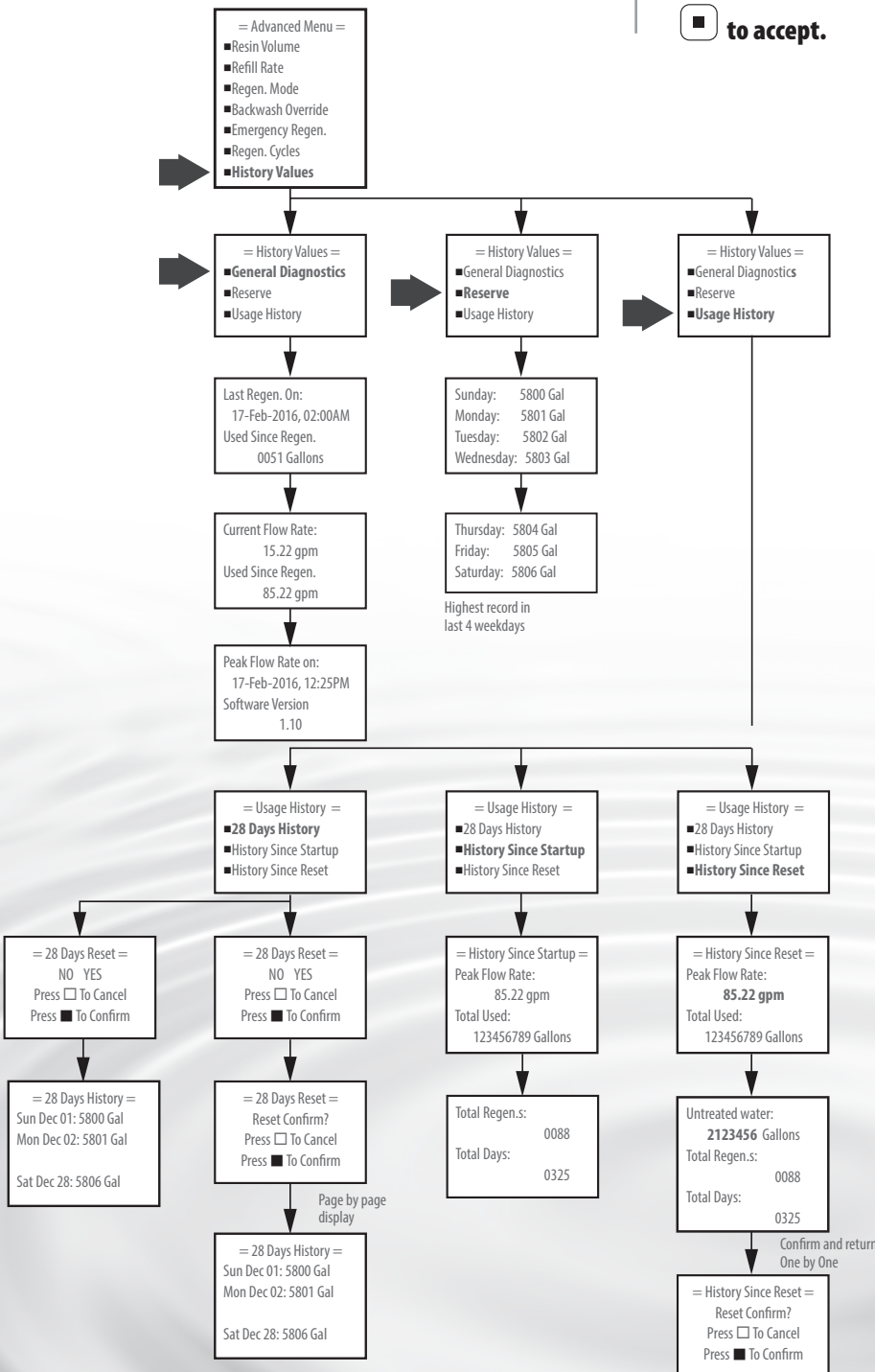

PARAMETER	DESCRIPTION
LAST REGEN ON	Date of last system regeneration.
USED SINCE REGEN	Volume used since last regeneration.
CURRENT FLOW RATE	The current system flow rate.
PEAK FLOW RATE	The peak or highest flow rate since last regeneration.
SOFTWARE VERSION	The software version programmed on the PCB.
RESERVE	The calculated reserve for each day based on the highest days usage over the past 4 weeks.
28 DAYS HISTORY	The volume used for each of the last 28 days.
USAGE HISTORY	The usage since system start up and from the last reset.
TOTAL USED	The total volume used.
TOTAL REGENS	The total quantity of regenerations.
TOTAL DAYS	The total days in operation.

REPLACE PISTON AND/OR BRINE VALVE ASSEMBLY

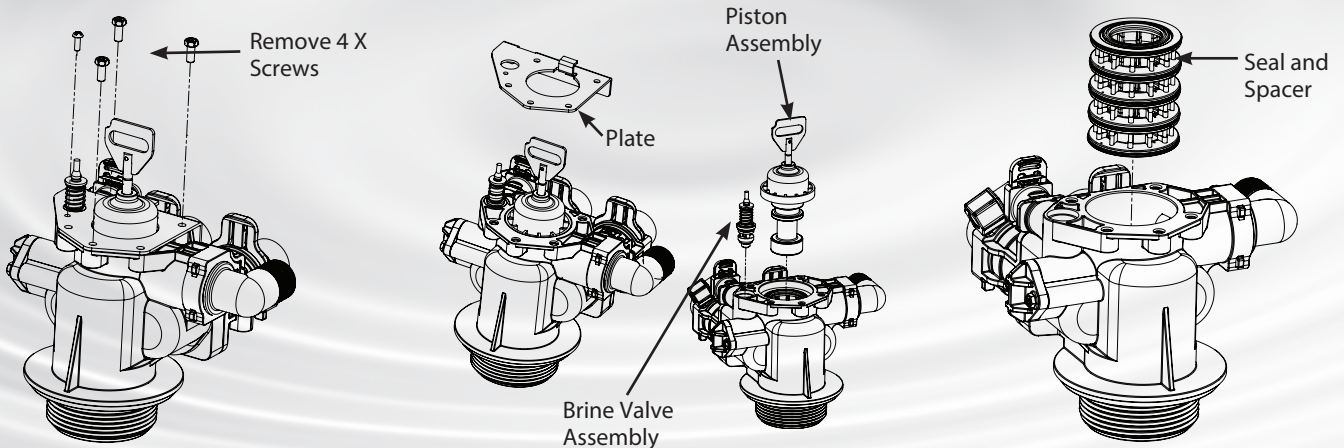

1. Follow steps 1 to 6 of timer /Powerhead replacement.
2. Remove four screws from the plate on the valve body.
3. Remove the plate from the valve body and pull the Piston Assembly from the valve. The brine valve assembly can also be removed in this stage.
4. Remove the seal spacer assembly, grease it with silicone lubricant and put back in.
5. Replace piston assembly followed by timer assembly.
6. Replace the piston assembly and reverse following steps in this section

CLEAN INJECTOR ASSEMBLY

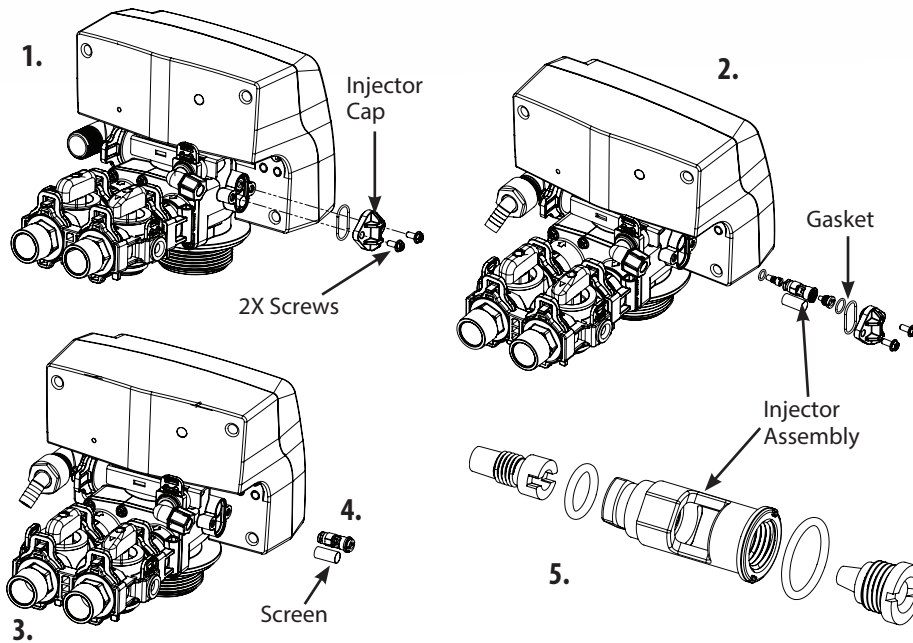

1. Remove the two screws from the injector cap
2. Pull the injector cap and gasket
3. Pull the injector assembly and screen
4. Replace/clean screen and injector assembly and put it back in the valve in appropriate location as shown
5. Put back the injector cap. Grease the injector assembly o-rings and injector cap gasket. Care should be taken to put all o-rings and gaskets in place and grease them so that they don't pinch

REPLACE TIMER

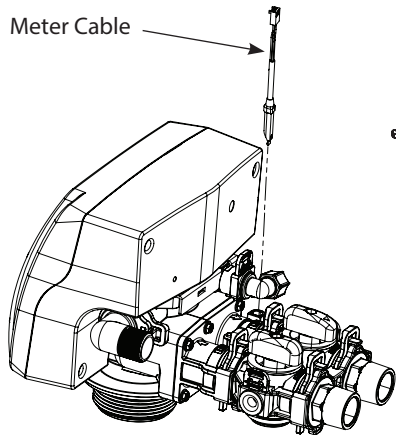

1. Disconnect the meter cable from the meter. (If flow meter is attached)

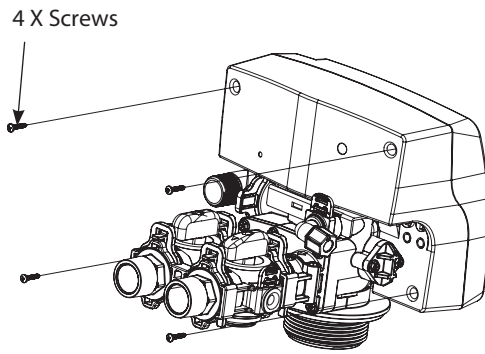

2. Remove four screws from the back of the valve cover

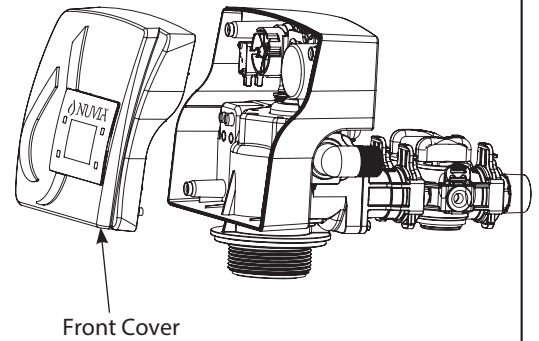

3. Remove the front cover of the valve.

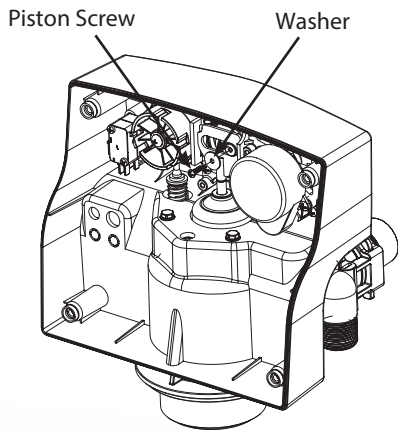

4. Remove the piston screw and washer from the piston rod.

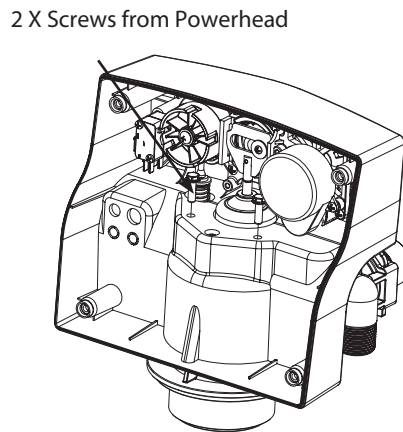

5. Remove the two screws from the powerhead as shown

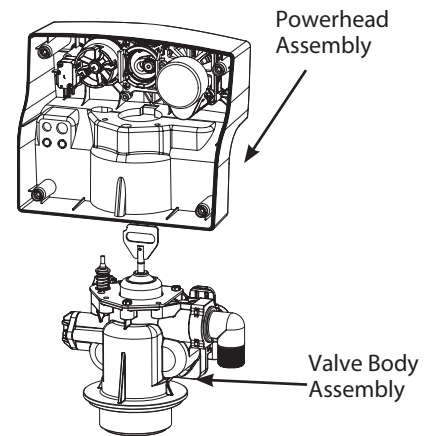

6. Lift the powerhead from the valve body assembly

7. Replace the powerhead by reverse following the steps in this section

REPLACE MOTOR

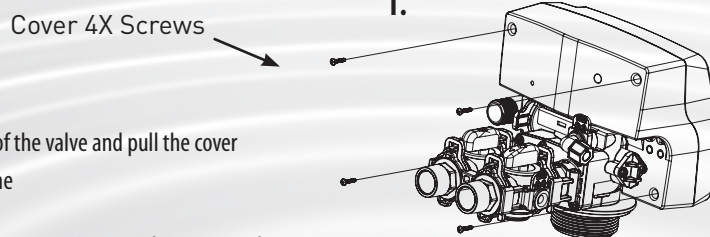

1. Remove Screws from the back of the valve and pull the cover

2. Remove all connections from the circuit board

3. Remove the two screws from the motor. Remove the motor and watch for the pin under the motor.

4. Replace the motor, connections and cover

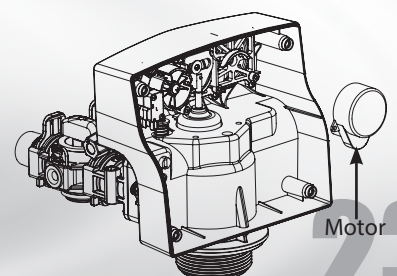
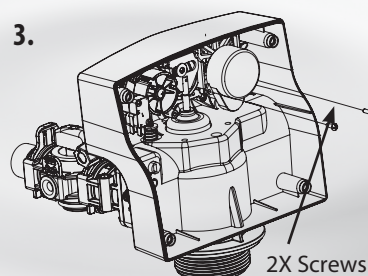
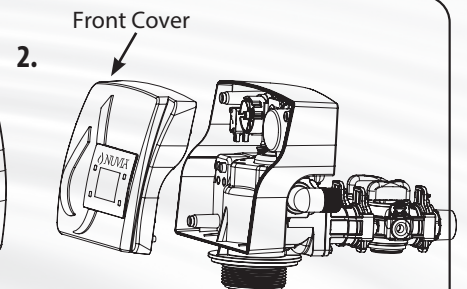

REPLACING THE BYPASS AND METER CABLE

Grey Meter Cable
60010267

60095101

Bypass comes with Meter
and Grey Meter Cable

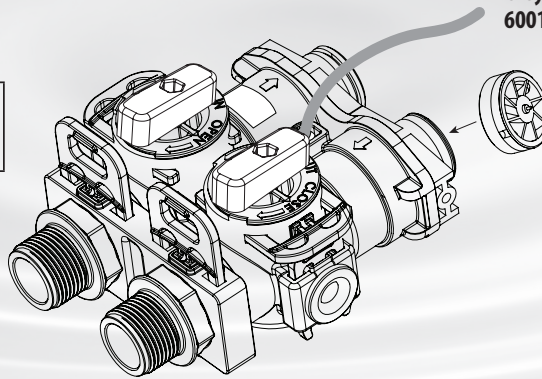

Step 1

Unplug the power from the wall socket.

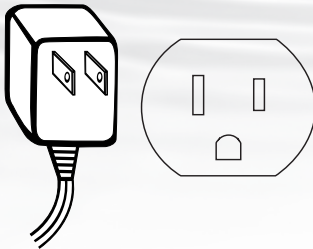

Step 2*

Remove 2 screws and clips from bypass.

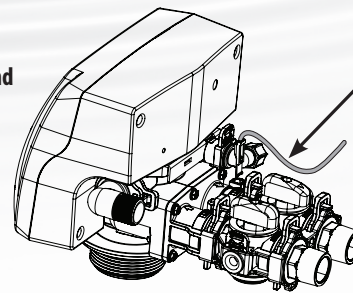

Disconnect the meter cable from the bypass.

*NOTE

Water to the household needs to be turned off and pressure relieved before Step 2

Step 3

Remove Cover.

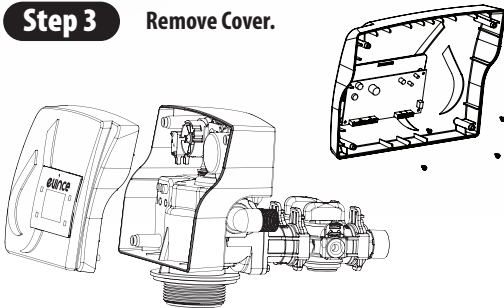

Step 4

Disconnect the cables from the front PCB display.

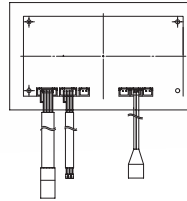

Step 5

Remove strain relief with pliers.

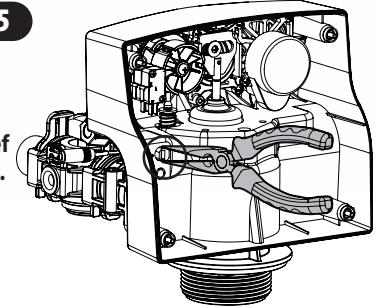

Step 6

Replace the old cable with the new Cable.

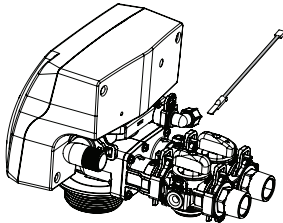

Step 7

Assemble the valve. Plug the power supply back into the wall socket.

*NOTE

For valve, meter ratio does not change

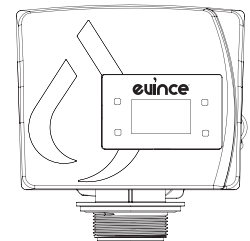

DISPLAY REPLACEMENT

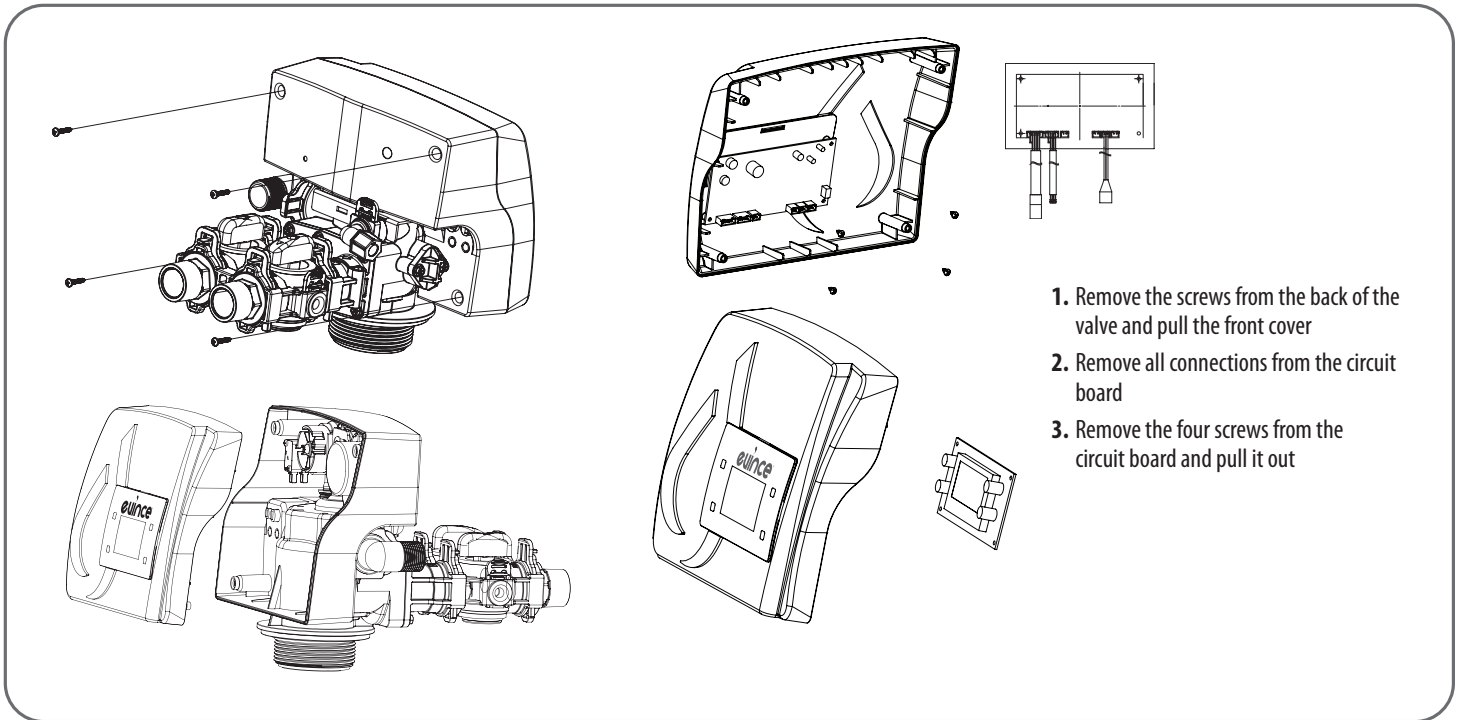

REPLACE MICROSWITCHES

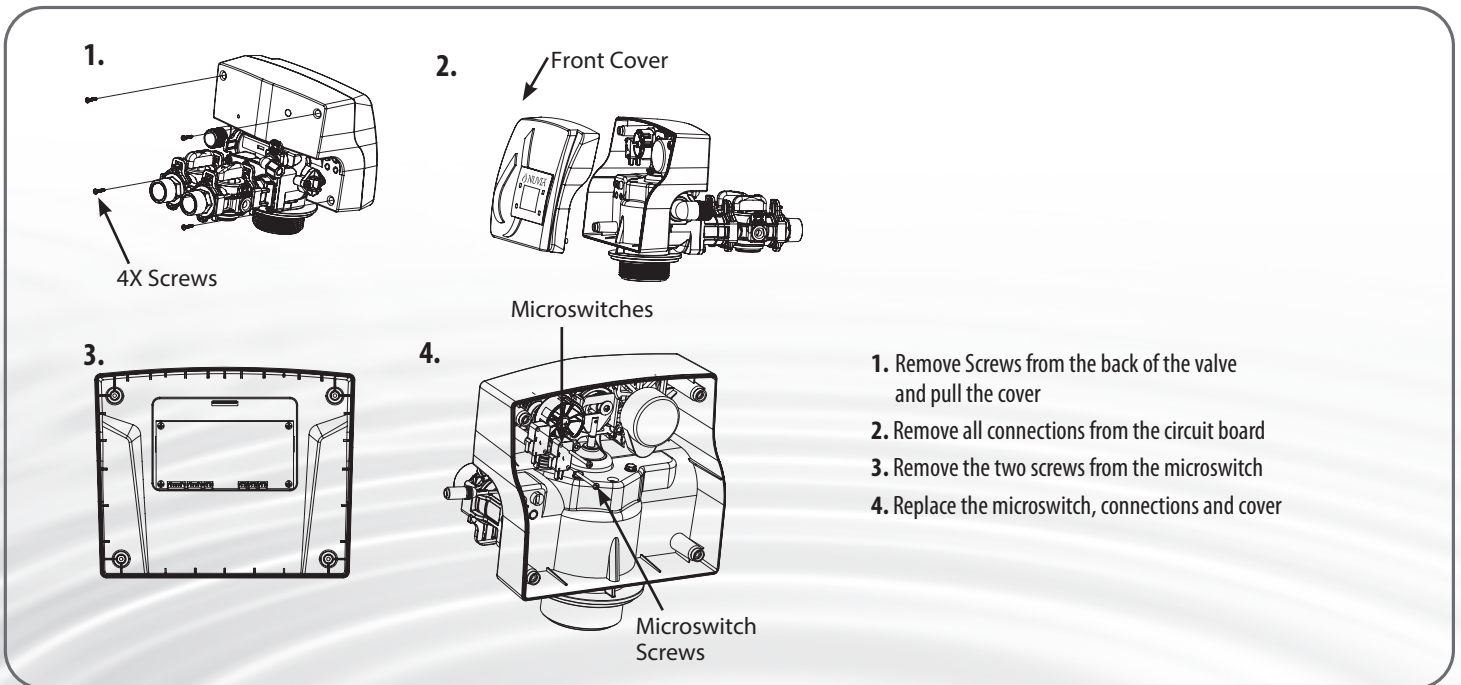

REPLACE DRAIN LINE FLOW CONTROL

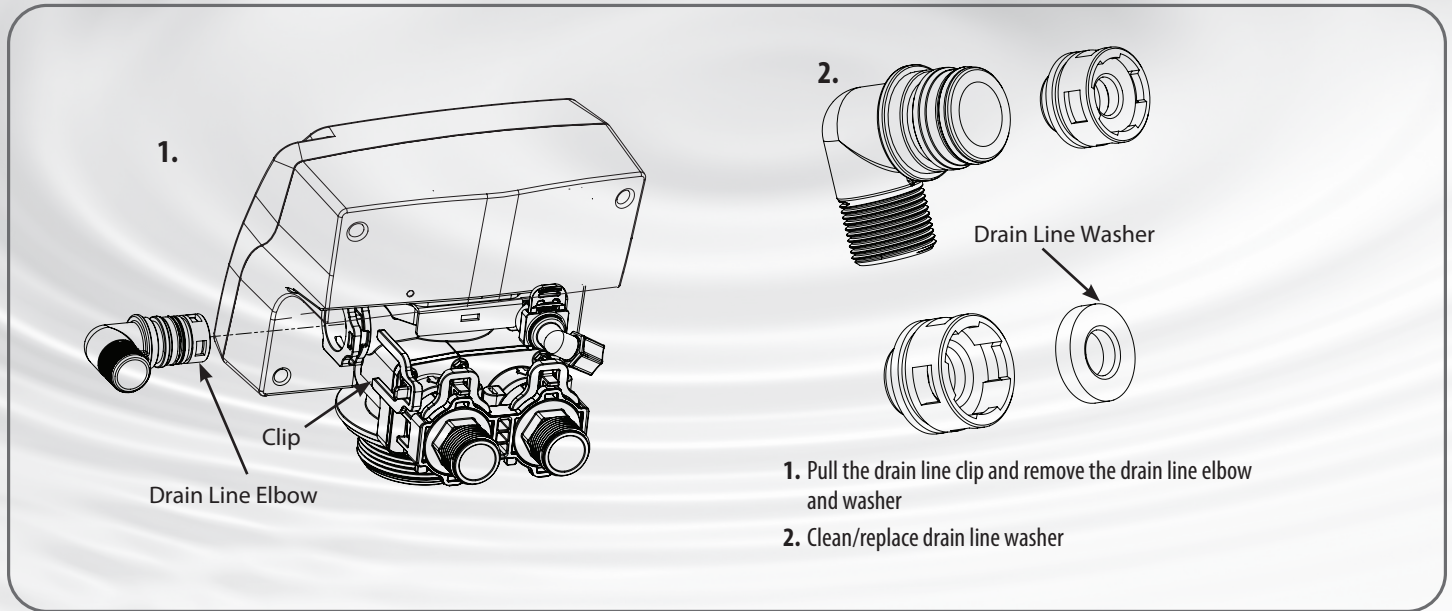

REPLACE BRINE LINE FLOW CONTROL

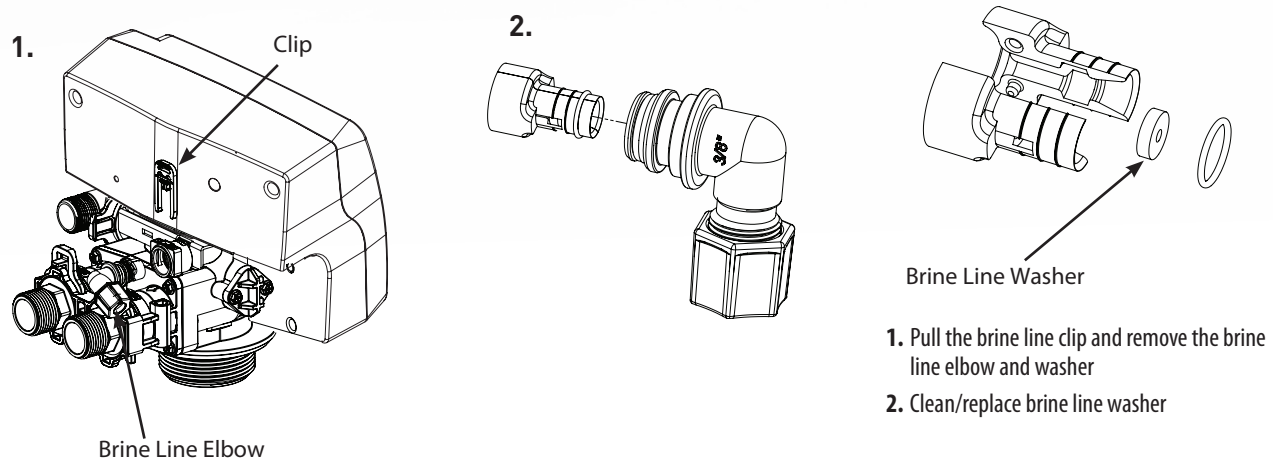

AFTER SERVICING

1. Reconnect drain line
2. Return bypass or inlet valve to normal in service position. Water pressure will automatically build in the refiner
3. Check for leaks at all sealed areas. Check drain seal with the control in the backwash position
4. Plug electrical cord into outlet
5. Set Time of Day and cycle the control valve manually to assure proper function. Make sure control valve is returned to the In Service position

NOTE

Be sure to shut off any bypass line.

PARTS BREAKDOWN

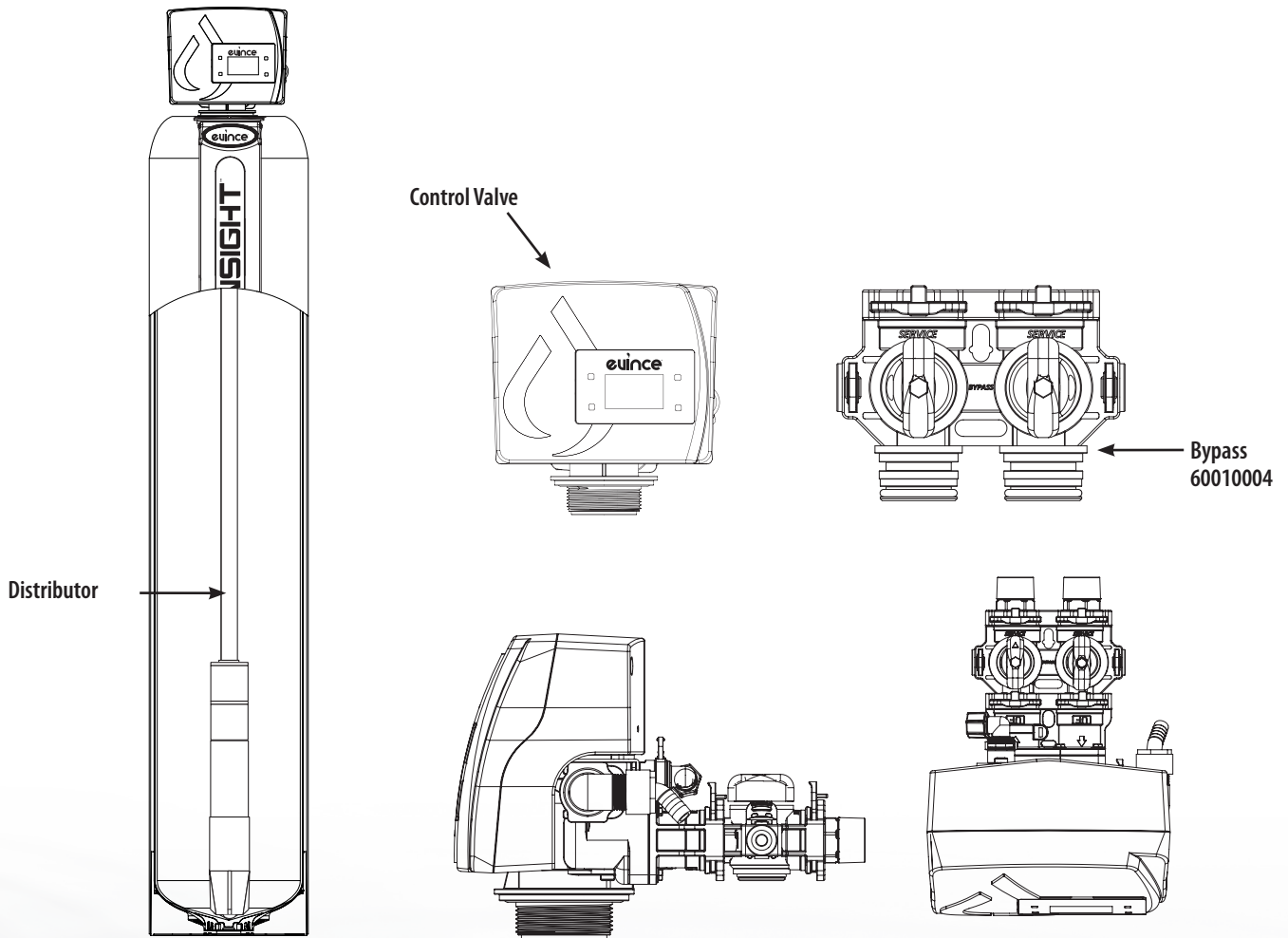

CONTROL VALVE

SYSTEM MODEL	PRESSURE TANK SIZE	DISTRIBUTOR #	CONTROL VALVE #
EV-IN-BW-948-1.0	9 x 48	25020213	940956
EV-IN-BW-1054-1.0	10 x 54	25020214	
EV-IN-BW-1252-1.0	12 x 52	25010060	
EV-IN-BW-1354-1.0	13 x 54	25010066	

PARTS BREAKDOWN

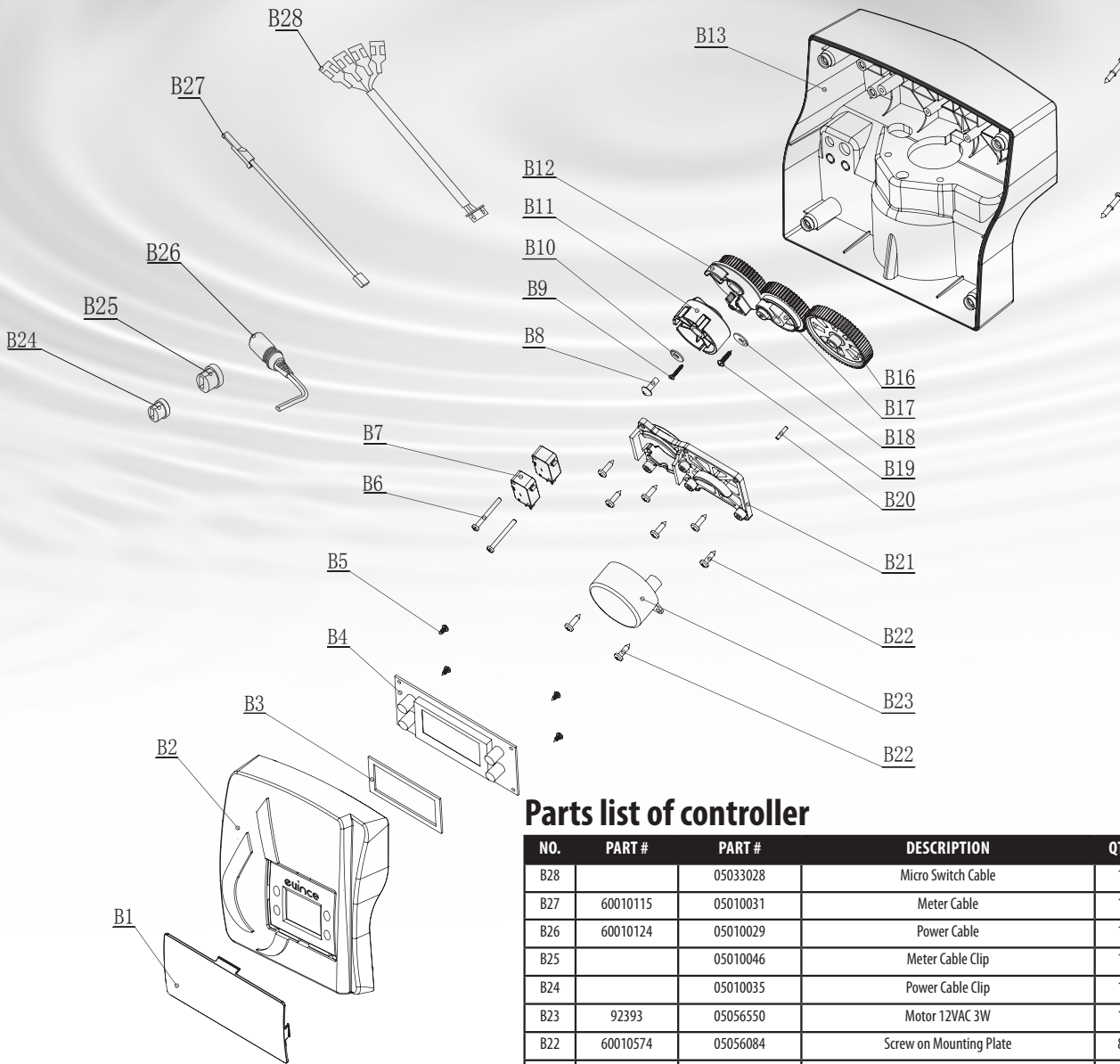

Parts list of controller

NO.	PART #	PART #	DESCRIPTION	QTY
B28		05033028	Micro Switch Cable	1
B27	60010115	05010031	Meter Cable	1
B26	60010124	05010029	Power Cable	1
B25		05010046	Meter Cable Clip	1
B24		05010035	Power Cable Clip	1
B23	92393	05056550	Motor 12VAC 3W	1
B22	60010574	05056084	Screw on Mounting Plate	8
B21		05031006	Mounting Plate	1
B20		05056098	Motor Pin	1
B19	60010099	13000426	Screw on Main Gear	1
B18	60010100	05056139	Washer on Main Gear	1
B17	92391	05031008	Main Gear	1
B16	92389	05030009	Drive Gear	1
B15		13000448	Screw on Back Cover	4
B14		13113051	Washers on Screw	4
B13		05033012B	Back Cover(White)	1
B12	92392	05031017	Brine Gear	1
B11		05033019	Locating wheel(UF)	1
B10		05056141B	Washer on Locating Wheel	1
B9		05033004	Screw 2.2×13	1
B8		05056166B	Screw on Locating Wheel	1
B7		05041011	Micro Switch	2
B6		13000332	Screws on Micro Switch	2
B5		13000401	Screws on PCB	4
B4	92388	05033008B	PCB	1
B3		05033027	PCB Absorb Shock Foam	1
B2		05033011F	Front Cover(White)	1
B1	DNR	05033007E	Controller Touch Panel(Evince®)	1

PARTS BREAKDOWN

Parts list of control valve body:

No.	Part # (Water Group)	Part # (Canature)	Description	Qty
A51	60010184	21389033	Brine Line Elbow Nut	1
A50	60010172	30020013M	Brine Line Elbow	1
A49	60010044	05056134	O-ring of Brine Line Elbow	1
A48	60010188	05031033	O-ring of BLFC Holder	1
A47	60010173	05031010M	BLFC Holder	2
A46	60010128	05056206M	BLFC(0.2GPM)(Optional)	1
A45	60010340	05033033	Brine Line Connector	1
A44	60010265	26010189	O-ring on Brine Line Connector	1
A43	60010099	13000426	Screw on Valve Bottom Connector	2
A42	60010599	07060007	Valve Bottom Connector	1
A41	60010080	26010103	Distributor O-ring	1
A40	60010598	05033021M	Central Pipe Adaptor	1
A39	60010597	26010038	O-ring of Central Pipe Adaptor	1
A38	60010077	05056063	Tank Mouth O-ring	1
A37	60010715	05033009	Screen 89 Valve	1
A36	60010595	05033020	Injector Cover	1
A35	60010341	26010101	O-ring of Injector Cover	1
A34	60010186	05031019	Big O-ring of Injector Holder	1
A33			Injector Nozzle(Optional)	1
A32	60010174	05031012M	Injector Holder	1
A31			Injector Throat(Optional)	1
A30	60010187	05031020	Small O-ring of Injector Holder	1
A29		05033010	89 Valve Body	1
A28	60010069	05056172N	Secure Clip Brine Line	1
A27	60010343	05033005B	End Plug Retainer	1
A26	60010076	05056088	Valve Body Connect Screws	2
A25	60010075	05056087	End Plug Retainer Screws	3
A24	60010574	05056084	Screw 3.5x13	1
A23	60032	05056180M	Brine Valve Injector Stem Assembly	1
A22		05033015	Spacer-89 Valve	8
A21		05033006	Seal-89 Valve	5
A20			Down Flow Piston-89 Valve	1
A19			92384 - UP PISTON ASSY	1
A18			92385 - FILTER PISTON ASSY	1
A17			End Plug-89 Valve	1
A16			Piston Rod-89 Valve	1
A15			Piston Assembly-89 Valve(Df)	1
A14			DLFC(2.4GPM)(Optional)	1
A13	60095694	05040030M	DLFC Holder	1
A12	60010211	05056121	O-ring on Drain Elbow	1
A11	60010253	05040130M	Drain Elbow 3/4" NPT	1
	60010254	05040131M	Drain Elbow 1" NPT	1
A10	60010227	05040018M	Secure Clip of Drain Line	1
A9	60010585	05005636M	Big O-ring of Adaptor Coupling	2
A8			Adaptor Coupling	2
A7			Small O-ring of Adaptor Coupling	2
A6	92387	05033022M	Adaptor Secure Clip	2
A5	60010589	05033013	89 Valve Connector	1
A4	60010596	05056508	Screws of Valve Connector	8
A3	60010238	02170055	Impeller Assembly	1
A2		05010019	Bush	2
A1	60010587	05010077	Impeller Holder	1

Seal and
Spacer Kit

92382

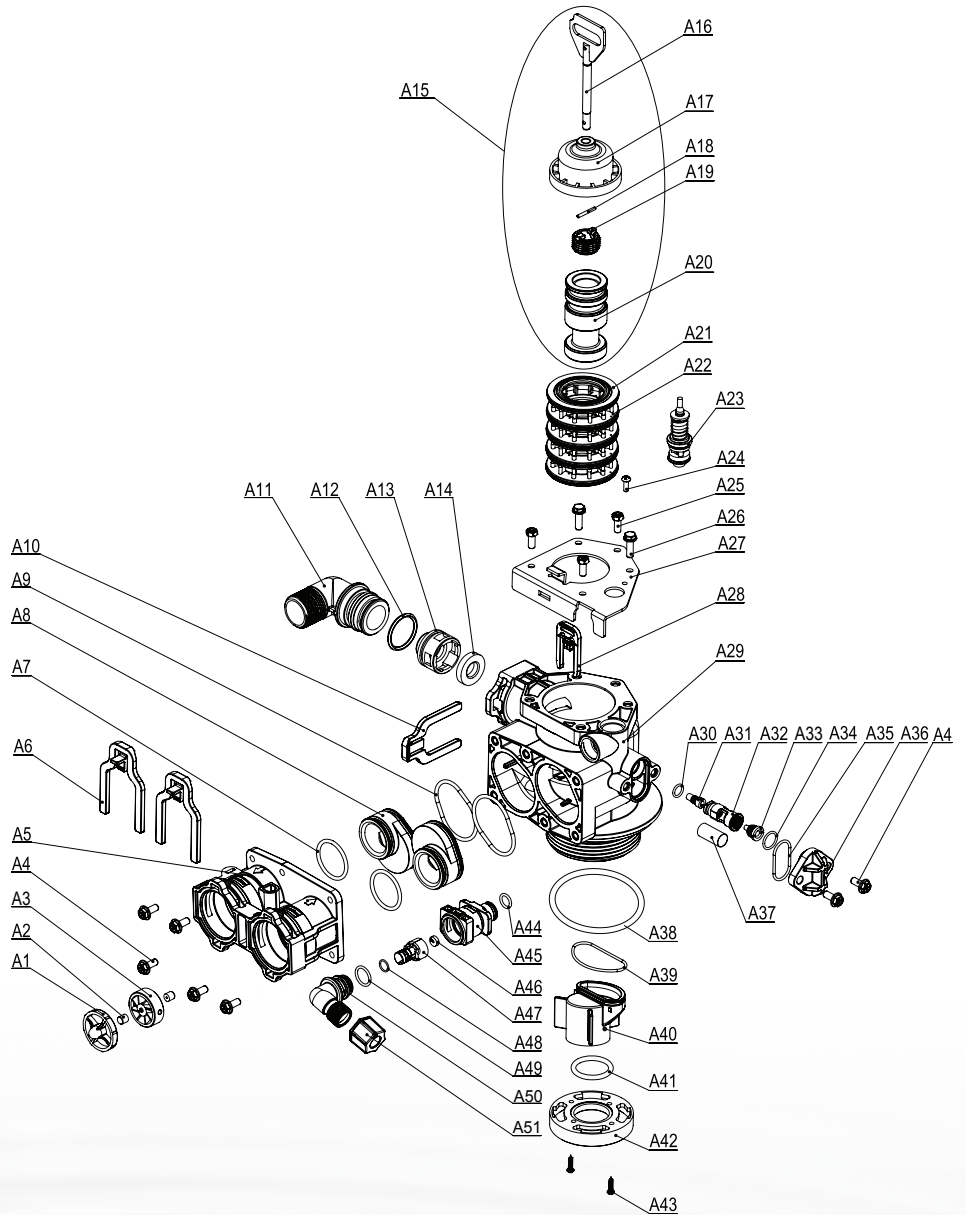

Item #s For All Injector Assemblies and Brine Line and Drain Line Washers

Injector
Assemblies

Part #	Part Description
60010110	BLFC BUTTON #2 0.3GPM A32
60010082*	BLFC BUTTON #2 0.7GPM A32
60010128	BLFC BUTTON 0.2GPM
60010601	INJECTOR SET #0000 BLACK THROAT
60010602	NOZZLE #0000 BLACK THROAT
60010603	INJECTOR SET #000 GREY THROAT
60010604	NOZZLE #000 GREY THROAT
60010605	INJECTOR SET #00 VIOLET THROAT
60010606	NOZZLE #00 VIOLET THROAT
60010607	INJECTOR SET #0 RED THROAT
60010608	NOZZLE #0 RED THROAT
60010609*	INJECTOR SET #1 WHITE THROAT
60010610*	NOZZLE #1 WHITE THROAT
60010611	INJECTOR SET #2 BLUE THROAT
60010612	NOZZLE #2 BLUE THROAT

Injector
Assemblies

Part #	Part Description
60010613	INJECTOR SET #3 YELLOW THROAT
60010614	NOZZLE #3 YELLOW THROAT
60010685	INJECTOR SET #4 GREEN THROAT
60010686	NOZZLE #4 GREEN THROAT
12052	1.4 GPM DLFC WASHER
12053	2.0 GPM DLFC WASHER
60010140	#45 5.0GPM
60010142	#75 7.0 GPM
60010143	#1 8.0 GPM
60010144	#2 11.0 GPM
60010145	#3 14.0 GPM
60010146	#4 17.0 GPM
60010147	#5 21.0 GPM
60010148	#6 24.0 GPM

* Default



TROUBLE SHOOTING GUIDE

Problem	Cause	Possible Solutions
1. FILTER BLEEDS TASTE AND ODOR OR SEDIMENT	<ul style="list-style-type: none"> A. Bypass valve is open B. Electrical service to unit has been interrupted C. Defective or stripped media bed D. Quality of water has worsened E. Filter capacity too small F. Filter not backwashing enough G. Excessive water usage - calendar clock models 	<ul style="list-style-type: none"> A. Close bypass valve B. Assure permanent electrical service (check fuse, plug or switch) C. Replace media D. Have water sample analyzed to determine any change E. Replace with larger unit or add another filter F. Be sure flow control is not clogged or drain line restricted. Be sure water pressure has not dropped and that pump has sufficient capacity G. Increase frequency of regeneration. Make sure there are no leaks in toilets or sinks
2. FILTER FAILS TO REGENERATE	<ul style="list-style-type: none"> A. Electrical service to unit has been interrupted B. Timer is defective C. Power failure D. Timer motor does not run 	<ul style="list-style-type: none"> A. Assure permanent electrical service (check fuse, plug or switch) B. Replace timer C. Reset time of day D. Replace defective motor
3. FILTER REGENERATES EVERY DAY	<ul style="list-style-type: none"> A. Faulty gear train 	<ul style="list-style-type: none"> A. Check the mechanical linkage on the timer control to eliminate possible binding in the gear train
4. LOSS OF WATER PRESSURE	<ul style="list-style-type: none"> A. Iron or turbidity build-up in filter B. Filter not regenerating often enough C. Not enough water volume or pressure to backwash properly 	<ul style="list-style-type: none"> A. Clean control and treat bed with Iron Out. Increase frequency of regeneration B. Increase frequency of regeneration C. Correct water supply problem
5. LOSS OF MEDIA THROUGH DRAIN LINE	<ul style="list-style-type: none"> A. Air in water system B. Backwash rate too fast 	<ul style="list-style-type: none"> A. Assure that well system has proper air eliminator control. Check for dry well condition B. Check drain flow control for proper flow rates
6. DRAIN FLOWS CONTINUOUSLY	<ul style="list-style-type: none"> A. Foreign material in control B. Timer motor stopped or jammed 	<ul style="list-style-type: none"> A. Remove piston assembly and inspect bore. Remove foreign material and check control in various regeneration positions B. Replace timer motor

Evince® warrants that your new water conditioner is built of quality material and workmanship. When properly installed and maintained, it will give years of trouble free service.

Ten Year Complete Parts Warranty

Evince® will replace any part which fails within 120 months from date of manufacture, as indicated by the serial number, provided the failure is due to manufacturer defect. The only exception shall be when proof of purchase or installation is provided and then the warranty period shall be from the date thereof.

Life Time Warranty on Mineral Tanks and Brine Tanks

Evince® will provide a replacement mineral tank or brine tank to any original equipment purchaser in possession of a tank that fails provided that the water conditioner is at all times operated in accordance with specifications and not subject to freezing or vacuum.

General Conditions

Damage to any part of this water conditioner or filter as a result of misuse, misapplication, neglect, alteration, accident, installation or operation contrary to our printed instructions, damage to ion exchange resin and seals caused by chlorine / chloramines in the water supply, or damage caused by any force of nature is not covered in this warranty. We will repair or replace defective parts if our warranty department determines it to be defective under the terms of this warranty. **Evince®** assumes no responsibility for consequential damage, labor or expense incurred as a result of a defect or failure.

Evince Water Group Inc.®

Direct Phone Number: 951.336.0966

1641 Commerce St.

Corona, CA 92878