

evince® | ELITE™

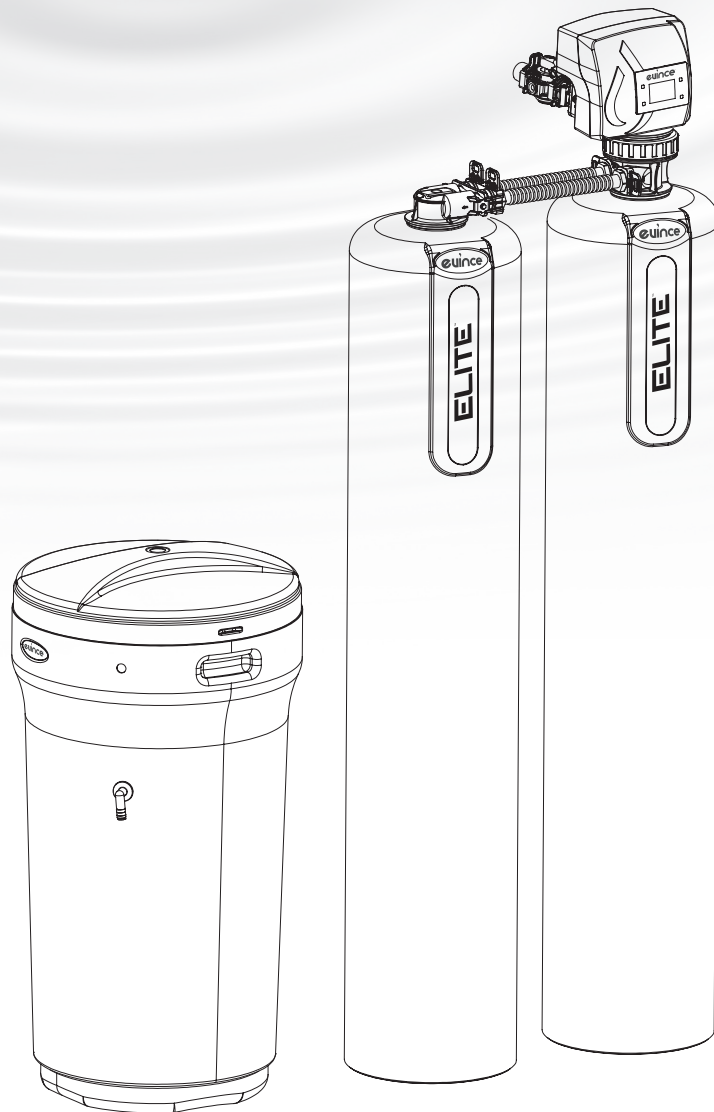

IAPMO R & T Certified
against CSA B483.1



IAPMO R & T Certified
against NSF/ANSI 44

- 1. Page 18 of this manual contains important maintenance procedures for the continued proper operation of your unit. These MUST be performed regularly for your warranty to remain valid.**
- 2. Read all instructions carefully before operation.**
- 3. Avoid pinched o-rings during installation by applying NSF certified lubricant to all seals (provided with install kit).**
- 4. This system is not intended for treating water that is microbiologically unsafe or of unknown quality without adequate disinfection before or after the system.**

Evince Water Group Inc.®

Direct Phone Number: 951.336.0966

1641 Commerce St.

Corona, CA 92878

Table of Contents

READ THIS PAGE FIRST BEFORE STARTING INSTALLATION	3
EFFICIENCY STATEMENT	4
SPECIFICATIONS	
SPECIFICATION	5
SYSTEM DIMENSIONS	6
BRINE TANK DIMENSIONS	6
INSTALLATION	
UNPACKING / INSPECTION OF TWIN TANK MODEL	7
BRINE TANK ASSEMBLY	9
CHECK VALVE TYPE AND VALVE SERIAL # BEFORE INSTALLATION	10 11
PREPARATIONS	12
INSTALLATION STEPS	13
WATER CONDITIONER INSTALLATION	14
OPERATION	
STARTUP INSTRUCTIONS	15
DURING REGENERATION / PLUMBING SYSTEM CLEAN-UP	17
MAINTENANCE INSTRUCTIONS AND SCHEDULE	18
IMPORTANT WARRANTY AND MAINTENANCE INFORMATION	19
RES-UP® FEEDER INSTALLATION INSTRUCTIONS (OPTIONAL)	20
SERVICING EVINCE ELEVATE VALVE	21
MASTER PROGRAMMING	22
DIAGNOSTIC SCREEN	24
REPLACEMENT	
REPLACE PISTON AND/OR BRINE VALVE ASSEMBLY / CLEAN INJECTOR ASSEMBLY	25
REPLACE TIMER / REPLACE MOTOR	26
REPLACING THE BYPASS AND METER CABLE	27
DISPLAY REPLACEMENT / REPLACE MICROSWITCHES	28
REPLACE DRAIN LINE FLOW CONTROL / REPLACE BRINE LINE FLOW CONTROL AFTER SERVICING	29 29
PARTS BREAKDOWN	30
POWERHEAD	31
VALVE BODY	32
TROUBLE SHOOTING GUIDE	33
MASTER PROGRAMMING GUIDE	34

READ THIS PAGE FIRST

BEFORE STARTING INSTALLATION

- ▶ Read this manual thoroughly to become familiar with the device and its capabilities before installing or operating your Water Conditioner. Failure to follow instructions in this manual could result in personal injury or property damage. This manual will also help you to get the most out of your conditioner.
- ▶ This system is intended for use on municipal water only and its installation must comply with all State, provincial or local regulations. Check with your local public works department for plumbing and sanitation codes. In the event the codes conflict with any content in this manual the local codes should be followed. Consult your licensed plumber for installation of this system.
- ▶ This water conditioner is designed to operate on pressures of 30 psi to 125 psi. If the water pressure is higher than the maximum use a pressure reducing valve in the water supply line to the conditioner.
- ▶ This unit is capable of operating at temperatures between 40°F and 110°F (4°C - 43°C). Do not use this water conditioner on hot water supplies.
- ▶ Do not install this unit where it may be exposed to wet weather, direct sunlight, or temperatures outside of the range specified above.
- ▶ Avoid pinched o-rings during installation by applying (provided with install kit) NSF certified lubricant to all seals.
- ▶ It is not uncommon for sediment, precipitated iron or hardness to be present in water supplies. Precipitated minerals or sediments can cause damage to the seals and piston. This is considered a harsh environment and the seals and piston would not be covered by warranty stated or otherwise.
- ▶ It is recommended to regularly inspect and service the control valve on an annual basis. Cleaning and or replacement of piston, seals, and or spacers may be necessary depending on how harsh the conditions are. An Annual Maintenance kit (Part # 60010565) is available for this purpose
- ▶ Do not use water that is microbiologically unsafe without adequate disinfection before or after this system.
- ▶ This publication is based on information available when approved for printing. Continuing design refinement could cause changes that may not be included in this publication. The manufacturer reserves the right to change the specifications referred to in this literature at any time, without prior notice.

INSTALL NOTES & SAFETY MESSAGES

Watch for the following messages in this manual:

NOTE

Do not remove or destroy the serial number. It must be referenced on request for warranty repair or replacement

NOTE: used to emphasize installation, operation or maintenance information which is important but does not present a hazard.



CAUTION!

Disassembly while under pressure can result in flooding.

CAUTION: used when failure to follow directions could result in damage to equipment or property.



WARNING!

ELECTRICAL SHOCK HAZARD! UNPLUG THE UNIT BEFORE REMOVING THE COVER OR ACCESSING ANY INTERNAL CONTROL PARTS

WARNING: used to indicate a hazard which could cause injury or death if ignored.

EFFICIENCY STATEMENT

This product is efficiency rated according to NSF/ANSI 44. The stated efficiencies are valid only at the specified Sodium Chloride dosages and maximum service flow rate.

PERFORMANCE DATA SHEET				
MODEL NUMBER	EV-ELT-948-1.0	EV-ELT-1054-1.0	EV-ELT-1252-1.0	EV-ELT-1354-1.25
QTY HIGH CAPACITY RESIN	1.0 FT3	1.5 FT3	2.0 FT3	2.5 FT3
RATED SERVICE FLOW (GPM)	11.0	11.2	12.4	12.6
PRESSURE DROP AT RATED SERVICE FLOW (PSI)	15.0	15.0	15.0	15.0
RATED SOFTENING CAPACITY (GRAINS)	13,629 @ 3LBS	20,443 @ 4.5LBS	27,258 @ 6LBS	34,072 @ 6LBS
EFFICIENCY (GRAINS/LB SALT)	4,543	4,543	4,543	4,543
MAX. FLOW RATE TO DRAIN (GPM)	2.0	2.4	3.5	4.0
WORKING PRESSURE	MIN. 20 - MAX. 125 PSI			
OPERATING TEMPERATURE	MIN 39 - MAX. 100 DEGREES FAHRENHEIT			

These refiners conform to NSF/ANSI 44 for the specific performance claims as verified and substantiated by test data. These models are efficiency rated. The efficiency rating is valid only at the stated salt dose and maximum service flow rate. They have a demand initiated regeneration (D.I.R.) feature that complies with specific performance specifications intended to minimize the amount of regenerant brine and water used in their operation. These refiners have a rated refiner efficiency of not less than 3350 grains of total hardness exchange per pound of salt (based on sodium chloride) and shall not deliver more salt than their listed ratings. The rated salt efficiency is measured by laboratory tests described in NSF/ANSI Standard 44. These tests represent the maximum possible efficiency that the systems can achieve. Operational efficiency is the actual efficiency after the system has been installed. It is typically less than the efficiency due to individual application factors including water hardness, water usage, and other contaminants that reduce the refiner's capacity. These systems are not intended for use with water that is microbiologically unsafe or of unknown quality without adequate disinfection before or after the system. For best results, use plain, white block salt. Refer to Installation/operation manual and warranty for further details on installation, parts and service, maintenance and further restrictions or limitations to the use of the product.



Certified by IAPMO R&T according to NSF/ANSI 44 for effective reduction of hardness (calcium and magnesium) as verified and substantiated by test data.

SPECIFICATION

All units are factory programmed to the below specifications. Alteration should only be done by a factory trained technician or after consultation with one of our technical representatives if you have any questions please contact:

Evince® Direct Phone Number: 951.734.7400
Service Related Matters: customerservice@Evincewater.com
General questions: info@Evincewater.com

Evince® Elite Automatic Water Refiners: Elite Series 1"

Specifications	EV-ELT-TT-948-1.0	EV-ELT-TT-1054-1.0	EV-ELT-TT-1252-1.0	EV-ELT-TT-1354-1.0
Optional - High Efficiency				
Sodium Used - Per Regeneration	3.0 lbs	4.5 lbs	6.0 lbs	7.5 lbs
Water Used - Regeneration	92.2 gal	120.9 gal	164.9 gal	171.3 gal
Hardness Removal - Grains	13,000	19,500	26,000	32,500
Factory Settings - Standard Capacity				
Sodium Used - Per Regeneration	6.0 lbs	9.0 lbs	12.0 lbs	15.0 lbs
Water Used - Regeneration	106.5 gal	143.9 gal	190.7 gal	196.7 gal
Hardness Removal - Grains	19,000	28,500	38,000	47,500
Optional - High Capacity				
Sodium Used - Per Regeneration	12.0 lbs	18.0 lbs	24.0 lbs	30.0 lbs
Water Used - Regeneration	109.6 gal	147.9 gal	196.8 gal	202.48 gal
Hardness Removal - Grains	27,000	40,500	54,000	67,500
Tank #1 EV-C12 - Cubic Feet	1.0 ft	1.5 ft	2.0 ft	2.5 ft ³
Tank #2 EV-UHC100 - Cubic Feet	1.0 ft	1.5 ft	2.0 ft	2.5 ft ³
EV-Macro Filtration Included:	Yes	Yes	Yes	Yes
EV-Clarification Included:	Yes	Yes	Yes	Yes
EV-Gold Filter included:	Yes in Tank 2	Yes in Tank 2	Yes in Tank 2	Yes in Tank 2
Tank Size	9x48	10x54	12x52	13x54
Tank Jacket / Media Loaded	Yes	Yes	No	No
Brine Tank / Cabinet Size (Inches)	18.7 x 34	18.7 x 34	18.7 x 34	18.7 x 34
Sodium Storage Capacity	240 lbs	240 lbs	240 lbs	240 lbs
Flow Rate @ 15 psi Pressure Drop	11.6 gpm	11.8 gpm	12.8 gpm	13.0 gpm
Flow Rate @ 25 psi Pressure Drop	15.8 gpm	15.9 gpm	17.1 gpm	17.2 gpm
Back Wash Flow Rate	2.0 gpm	2.4 gpm	3.5 gpm	4.0 gpm
Shipping Weight	122 lbs	155 lbs	172 lbs	208 lbs
Regeneration Type	Dynamic Regeneration			
Maximum Efficiency	4,333 grains /lb sodium			
Plumbing Connections	Includes 1"90°Elbows & 1" Straight NPT			
Media Type	EV-Macro Filtration - Tank 1 and 2 EV-C12 Ultra Refiner - Tank 1 EV-Clarification - Tank 1 and 2 EV-Gold Filter - Tank 2 EV-UHC100 Hydro Conditioning - Tank 2			
Electrical Requirements	Input 120V 60 Hz - Output 12V 650mA			
Water Temperature	Min 39 - Max. 100 degrees Fahrenheit			
Water Pressure	Min. 20 - Max. 125 psi			

Note: Evince® Systems can be installed into homes and small commercial applications with up to 1.25" plumbing. Optional 1.25" connections available upon request.

Working Temperature: This unit must be operated at temperatures between 40°F and 110°F (4°C - 43°C).

Working Pressure: This water refiner must be operated on pressures between 30 psi to 125 psi. If the water pressure is higher than 125 PSI, use a pressure reducing valve in the water supply line to the refiner.

Voltage = 120V / 60 Hz

Pipe Size = 3/4", 1" and 1.25"

- At the stated service flow rates, the pressure drop through these devices will not exceed 15 psig.
- The manufacturer reserves the right to make product improvements which may deviate from the specifications and descriptions stated herein, without obligation to change previously manufactured products or to note the change.

* Do not use water that is microbiologically unsafe without adequate disinfection before or after the system.

Peak flow rates intended for intermittent use only (10 minutes or less) and are for residential applications only. Do not use peak flow rate for commercial applications or for a continuous rate when treated water supplies are geothermal heat pump, swimming pool, etc.

For satisfactory operation, the pumping rate of the well system must equal or exceed indicated backwash flow rate.

All units come with plastic bypass

Maximum Iron = 1.5 ppm

Maximum Hydrogen Sulfide = 0.0 ppm

Maximum Manganese = .75 ppm

pH = 6.5 to 8.5

SYSTEM DIMENSIONS

Models	A (Inches)	B (Inches)	C (Inches)
EV-ELT-TT-948-1.0	59 3/4"	9"	13"
EV-ELT-TT-1054-1.0	65 3/4"	10"	13"
EV-ELT-TT-1252-1.0	63 3/4"	12"	13"
EV-ELT-TT-1354-1.0	65 3/4"	13"	13"

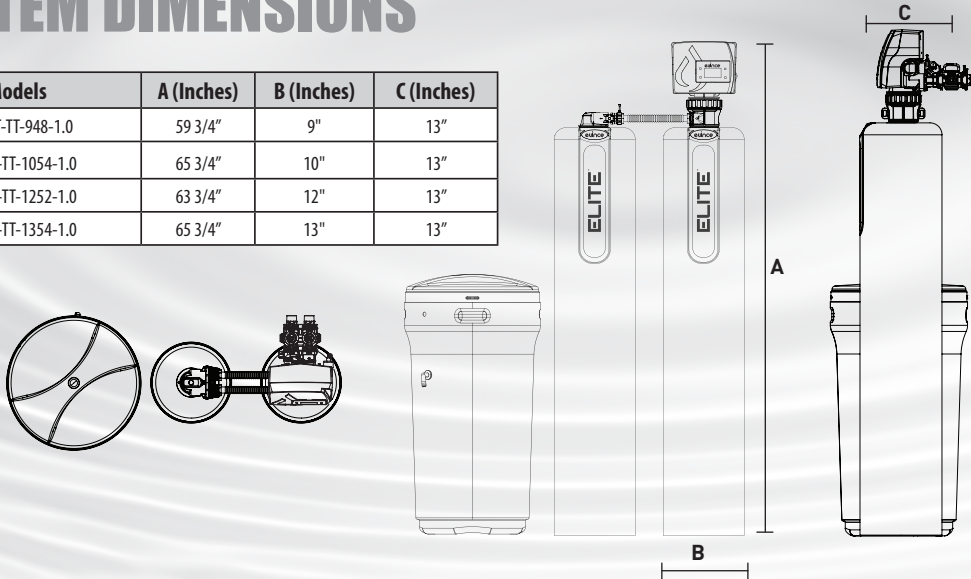

BRINE TANK DIMENSIONS

Model	Liquid Volume		Tank Dimensions (inches)	5 Pack Carton Dimensions (inches)	Salt Capacity		5 Pack Carton Shipping Weight	
	US Gal	Liters	L x W x H	L x W x H	Lbs	Kg	Lbs	Kg
Brine Tanks								
BTR-100	29.5	111.5	18.1 x 34.7	18.9 x 18.9 x 65.6	270.0	122.2	52.8	23.9
BTR-145	42.3	159.7	20.3 x 37.4	21.9 x 21.9 x 72.2	385.0	174.2	65.6	29.8
BTR-200	53.0	200.3	23.0 x 40.5	24.6 x 24.6 x 84	700.0	316.7	125.0	56.6

* All brine tanks come with salt grid, safety float and brine well

BTR100

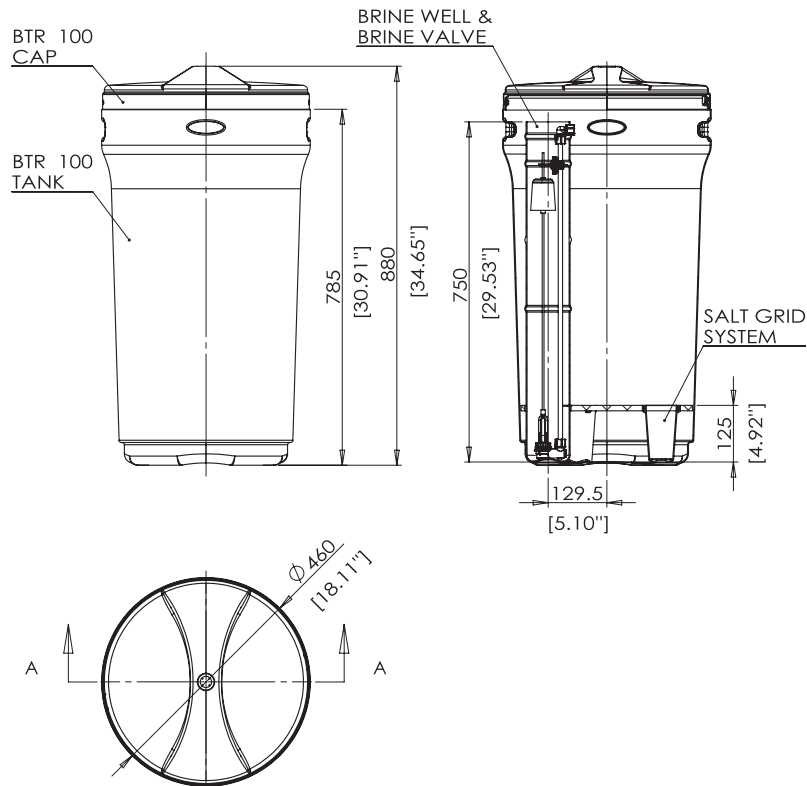

UNPACKING / INSPECTION OF TWIN TANK MODEL

SYSTEM CONTENTS:

MODELS:
 EV-ELT-948-1.0
 EV-ELT-1054-1.0
 EV-ELT-1252-1.0
 EV-ELT-1354-1.0

- YOU WILL EXPECT THE FOLLOWING.**
SHIPPING CARTON QUANTITY – 1
1. Control Valve*
 2. Tank
 3. Parts Box
 4. Owners Manual
 5. Drain Hose & Clamp (Not included in some brands)
 6. Parts Bag

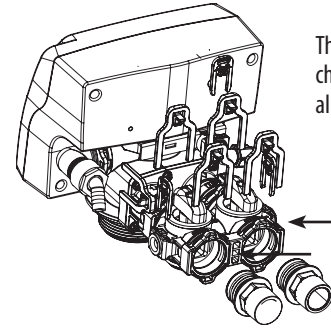
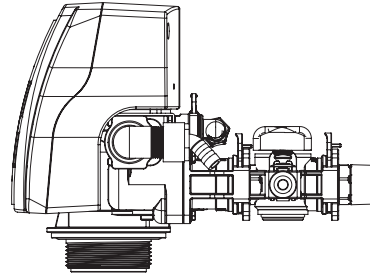

There are 8 black clips. Please check to make sure you have all of them.

Bypass (not attached)

1. Control Valve

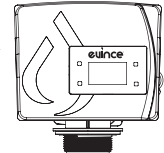

Parallel Adapter

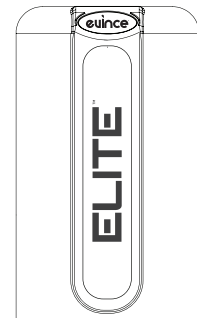
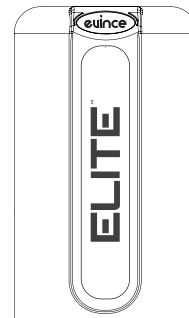
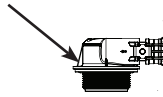

7. Tank 1 C/w Adapter

2. Tank 2 C/w Parallel Adapter

3. Parts Box

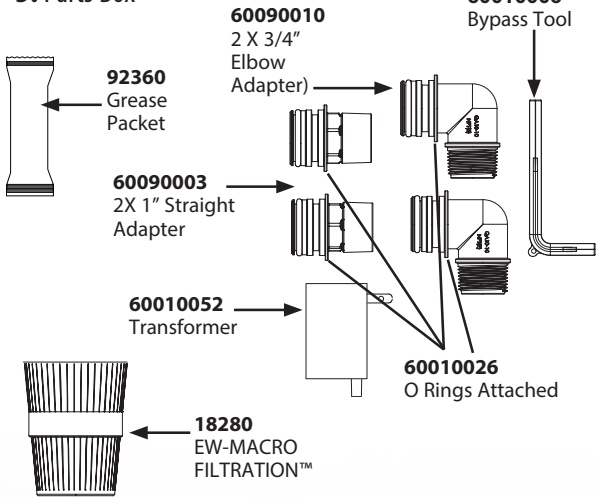

Brine Tank Assembly (Round Brine Tank Shown)

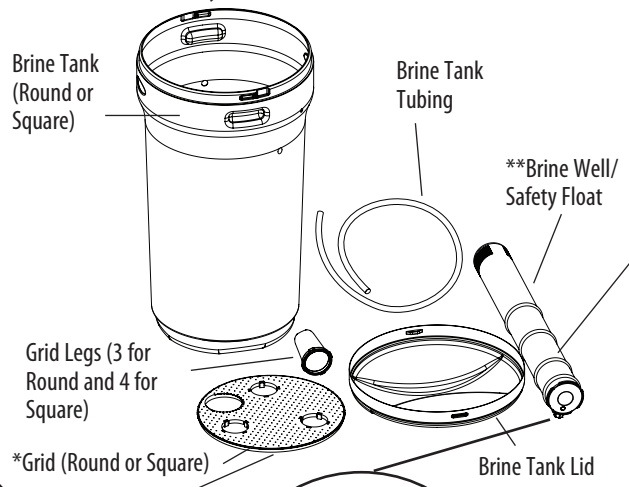

**FLOAT ASSY
 55010023 - BTR100

*GRID
 55010013 - For BTR 100

IMPORTANT:
 PLEASE ENSURE THE ATTACHED
 TUBE STIFFENER IS INSERTED
 INTO THE BRINE LINE BEFORE
 TIGHTENING THE NUT.

Tube Stiffener Part #
 10332

6. Parts bag

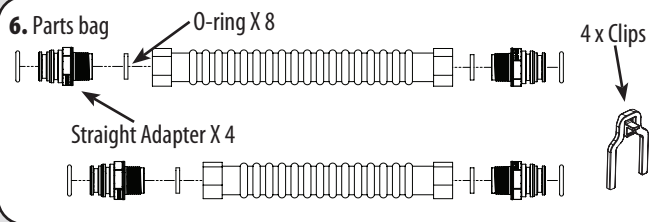

Straight Adapter X 4

4 x Clips

UNPACKING & INSPECTION

For Models EV-ELT-1252-1.0 and EV-ELT-1354-1.0, the media and Control Valve is packaged separately in carton and bags

WHAT IS INCLUDED WITH EV-ELT-1252-1.0 AND EV-ELT-1354-1.0 MODELS?

YOU WILL EXPECT THE FOLLOWING.

SHIPPING CARTON QUANTITY – 1

1. Tank # 2 c/w Adapter
2. Qty 6 of Media Boxes - Number of media boxes dependent on size of unit purchased. EV-ELT-948-1.0 and EV-ELT-1054-1.0 come with preloaded tanks
3. Drain Line and Hose Clamp (Not Included with some models)
4. Control Valve with Parts Box
5. Parts Bag

4. Control Valve

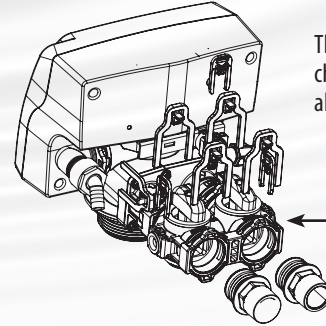
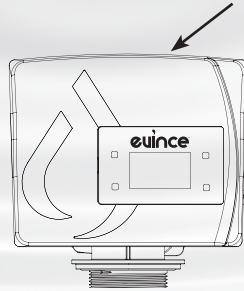

There are 8 black clips. Please check to make sure you have all of them.

Bypass (not attached)

2. Media Box

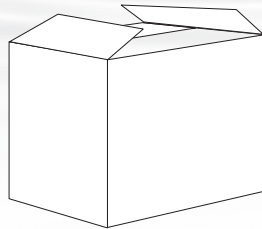

O-ring Part # 60010077

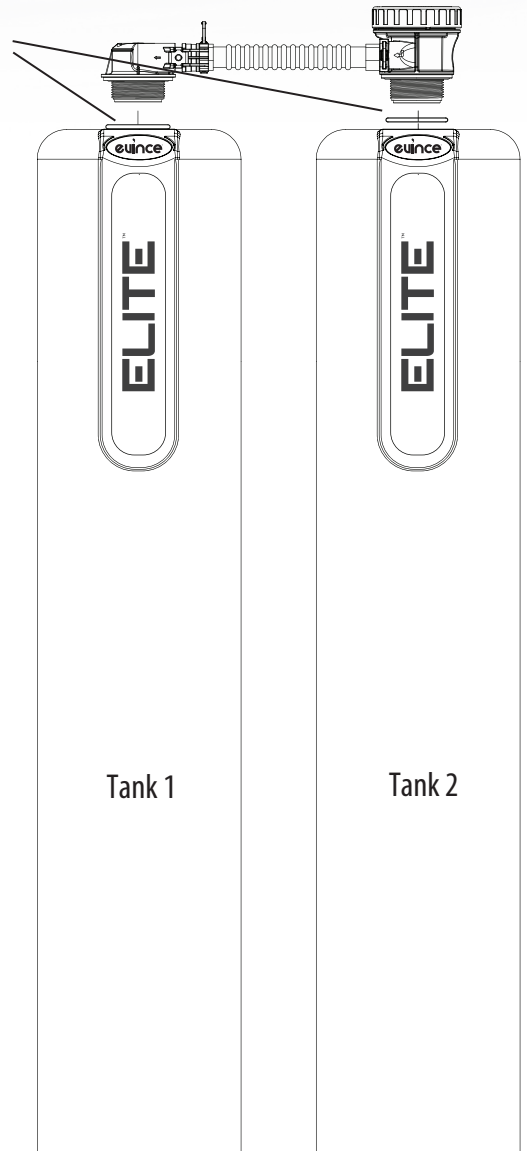

3. Parts Box

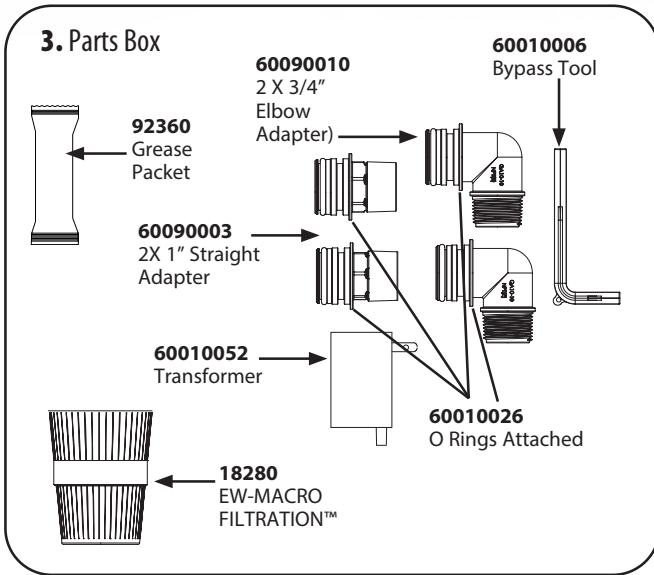

5. Parts bag

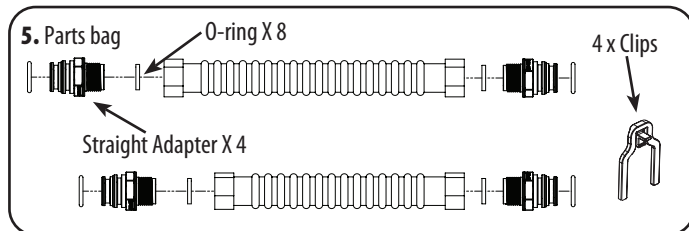

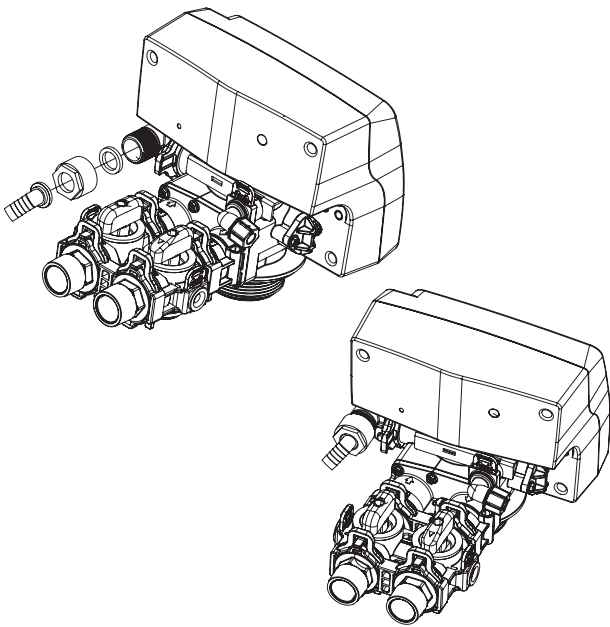

Pipe connector - 14" - 18" / 8" - 12" Tanks

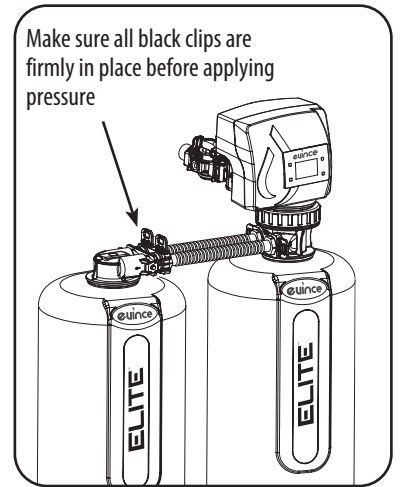
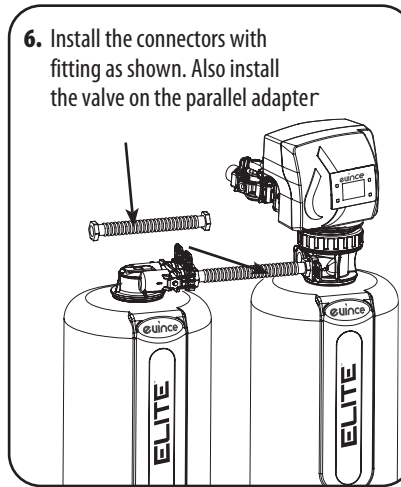
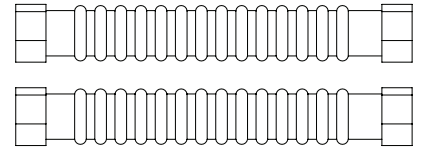

BRINE TANK ASSEMBLY

a) Attach the three brine grid legs to grid plate. The legs will snap on to the tabs of the salt plate making a "clicking" sound. Square brine tanks have four legs.

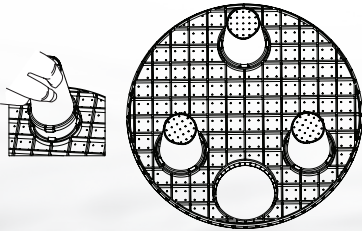

b) Insert the brine well assembly inside the grid plate in the hole provided.

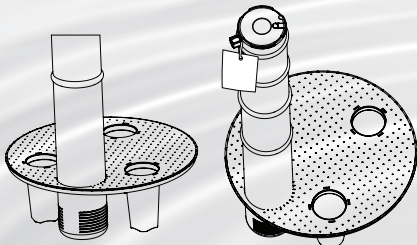

c) Drop the brine grid with brine well inside the brine tank such that the nut fitting faces the hole on the brine tank. Then press the grid down evenly inside the brine tank until the brine grid legs touches the bottom of the brine tank.

IMPORTANT: IT IS IMPORTANT TO ALIGN THE HANDLE TO THE BRINE WELL AS SHOWN

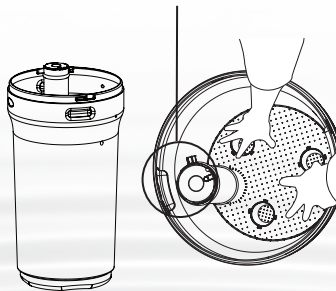

The hole in the brine tank should line up with the brine line as shown

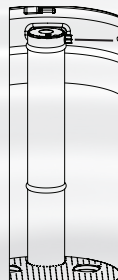

d) Take the brine tube and insert the nut and plastic sleeve as shown below.

Insert Sleeve

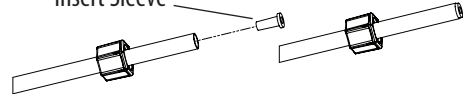

e) Insert the tube in the float assembly elbow and hand tighten the nut. In many cases the brine line already comes installed from the factory. Leave the other end of the brine line tube inside the brine tank until you are ready to connect to the control valve on the installation site.

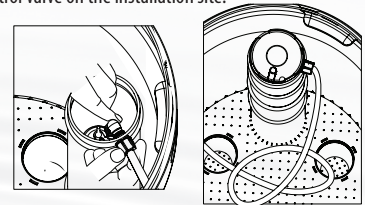

f) Once at the installation site, pull the other end of the brine tube from the hole on the brine tank. The completed assembly is shown below.

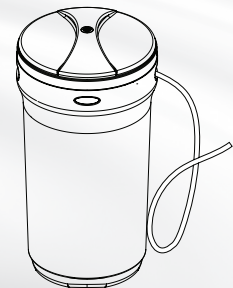

NOTE

Resin Cleaner

An approved resin cleaner **MUST** be used on a regular basis if your water supply contains iron.

See Res-Up® Feeder Installation Instructions in subsequent pages in this manual.

CHECK VALVE TYPE AND VALVE SERIAL

Check to make sure Valve Type is Upflow (UF) (left Sticker shown below). The right Sticker shows the serial # of the control valve. The middle sticker is a dataplate which provides information of Serial # and Date of Manufacture of complete system. Both Serial # labels are important for troubleshooting.

Please record these numbers on the back page of this manual for future reference.



Valve Serial # _____



Complete System Serial #

BEFORE INSTALLATION

Make sure you have a copy of your most recent water test results. If your water has not been tested previously you can contact your supplier of this product to obtain a water sample bottle to be sent to one of our facilities for a free analysis. **It is important that this product not be installed until you have this information.**

In all cases where metal pipe was originally used and is later interrupted by poly pipe or the Noryl bypass valve or by physical separation, an approved ground clamp with no less than #6 copper conductor must be used for continuity, to maintain proper metallic pipe bonding.

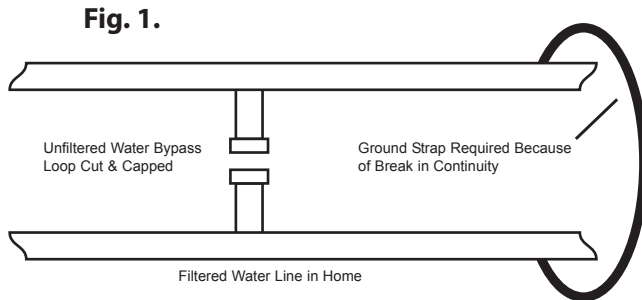

Inspecting and Handling Your EV-ELT Filter*

Inspect the equipment for any shipping damage. If damaged, notify the transportation company and request a damage inspection. Damage to cartons should also be noted.

Handle the filter unit with care. Damage can result if it is dropped or set on sharp, uneven projections on the floor.

Do not turn the filter unit upside down.

To Insure this Product Functions Properly:

Your feed water line size to the unit must be a minimum of 3/4 inch with an operating pressure of no less than 30 psi and no more than 125 psi.

MECHANICAL:

Do not use petroleum based lubricants such as petroleum jelly, oils or hydrocarbon based lubricants. Use only 100% silicone lubricants (grease packet provided in parts kit). All plastic connections should be hand tightened only. Teflon tape may be used on connections that do not use an O-ring seal. Do not use pliers or pipe wrenches except where indicated by Nut shape (eg. pipe adapters) All plumbing must be completed according to local codes. Soldering connections should be done before connecting any pieces to the pipe as excessive heat can damage them.

Tools Required for Installation:

NOTE: We recommend installation only be completed by a competent installer or plumbing professional to insure this product is installed in accordance with local plumbing codes.

- ▶ Two adjustable wrenches
- ▶ Additional tools may be required if modification to home plumbing is required.
- ▶ Plastic inlet and outlet fittings are included with the filter. To maintain full valve flow, 3/4" or 1" pipes to and from the filter fittings are recommended. You should maintain the same, or larger, pipe size as the water supply pipe, up to the filter inlet and outlet.
- ▶ Use copper, brass, or PEX pipe and fittings.
- ▶ Some codes may also allow PVC plastic pipe.
- ▶ ALWAYS install the included bypass valve, or 3 shut-off valves. Bypass valves let you turn off water to the filter for repairs if needed, but still have water in the house pipes.
- ▶ 5/8" OD drain line is needed for the valve drain. A 10' length of hose is not included with some brands.

NOTE

All government codes and regulations governing the installation of these devices must be observed.



CAUTION!

If the ground from the electrical panel or breaker box to the water meter or underground copper pipe is tied to the copper water lines and these lines are cut during installation of the Noryl bypass valve and/or poly pipe, an approved grounding strap must be used between the two lines that have been cut in order to maintain continuity. The length of the grounding strap will depend upon the number of units being installed and/or the amount of copper pipe being replaced with plastic pipe.

See Fig. 1.

NOTE

Check your local electrical code for the correct clamp and cable size.

NOTE

If a severe loss in water pressure is observed when the filter unit is initially placed in service, the filter tank may have been laid on its side during transit. If this occurs, backwash the filter to "reclassify" the media.

*NOTE

Due to transportation and climatic conditions all connections including the valve to the tank need to be checked at time of installation and tightened if necessary.

PREPARATIONS

- Media Installation (When Necessary).** Models larger than 2.0 CF of media are shipped with separate media in pails or boxes. Models lower than 1.5 CF of media come loaded with media and this step can be skipped for new installation.



The unit should be depressurized before installing or replacing media

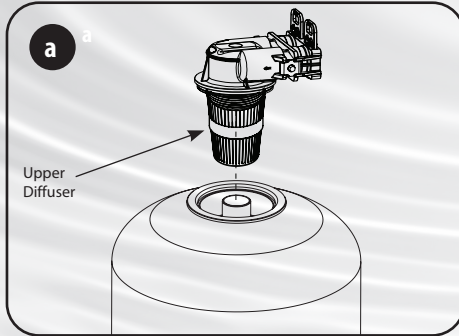

- Remove the adaptor from the mineral tank. Grease the bottom oring of the adaptor with silicone grease provided

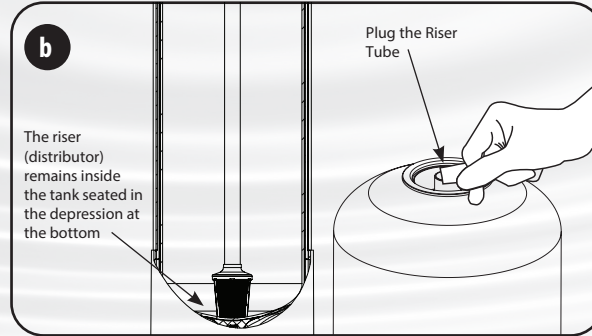
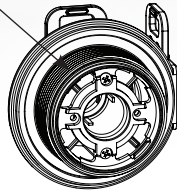

- Temporarily plug the open end of the riser tube to ensure that no resin or gravel falls down into the distribution. The riser (distributor) remains inside the tank seated in the depression at the bottom.
Plug tube with a tape. Remove after media is loaded.

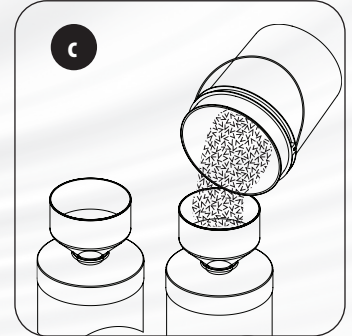

- Fill support bed first. The media will not always spill down inside the tank and may need to be swept inside.
The large funnel (sold separately) makes filling the tank easier and neater. (Or an empty 1 gallon or 4 liter container with the bottom cut out makes a good funnel.)

Locate Water Conditioning Equipment Correctly

Select the location of your filter tank with care. Various conditions which contribute to proper location are as follows:

- Locate as close as possible to the water supply source.
- Locate as close as possible to a floor or laundry tub drain.
- Locate in correct relationship to other water conditioning equipment. if closer than 10 feet please install check valve in accordance with local plumbing codes.
- Conditioners should be located in the supply line before the water heater. Temperatures above 110°F (43°C) will cause damage to conditioners.
- Do not install a filter or filter in a location where freezing temperatures occur. Freezing may cause permanent damage to this type of equipment and will void the factory warranty.
- Allow sufficient space around the unit for easy servicing.
- Keep the filter out of direct sunlight. The sun's heat may soften and distort plastic parts.

NOTE

Never make a direct connection into a waste drain. A physical air gap of at least 1.5" should be used to avoid bacteria and wastewater travelling back through the drain line into the softener.

NOTE

The unit is not ready for service until you complete the start-up instructions, page 15.

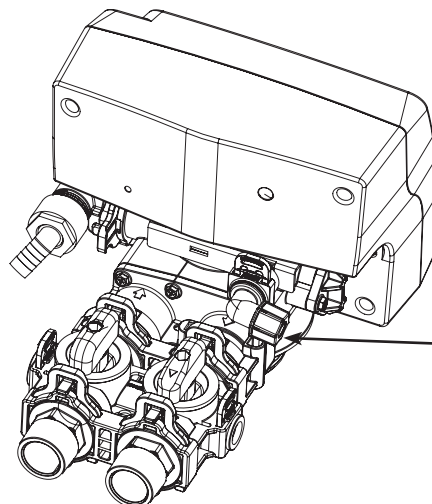

Make sure both brass and plastic nuts are tightened well

INSTALLATION STEPS

1. Determine the best location for your water filter, bearing in mind the location of your water supply lines, drain line and 120 volt AC electrical outlet. Subjecting the filter to freezing or temperatures above 43°C (110°F) will void the warranty.

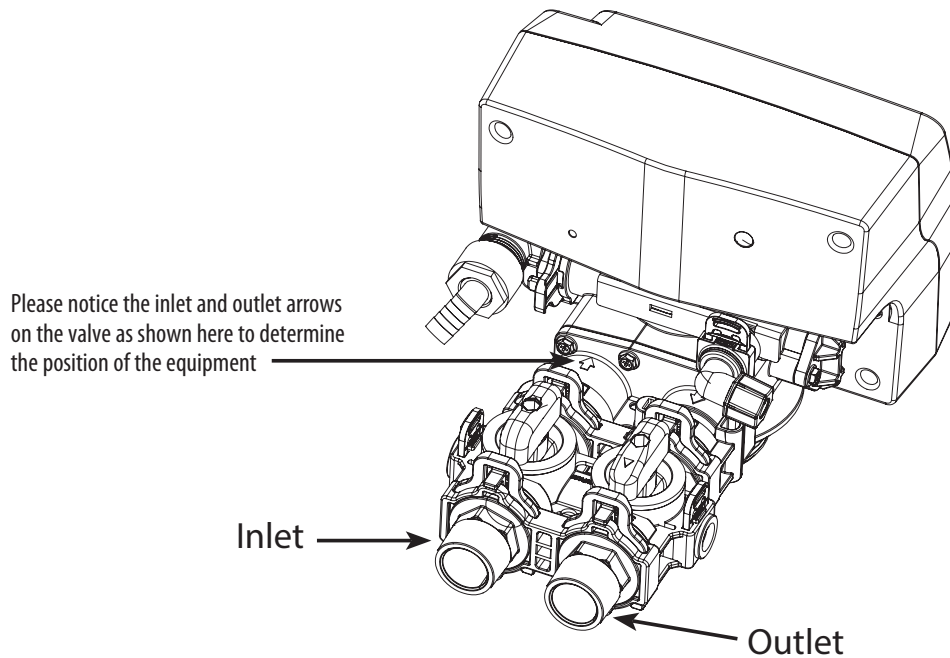

Facts to Remember When Planning Your Installation

1. All installation procedures must conform to local and state or provincial plumbing codes.
2. Outside faucets used to water lawns and gardens should not supply untreated water, replace untreated water with feed water to the unit. If necessary to do this please install check valve, see page 14. A new water line is often required to be connected to supply untreated water to the inlet of the water filter and to the outside faucets.
3. Make sure the bypass is attached well to the control valve. Connect the straight or elbow connectors to the bypass with red clips. Connect the inlet and outlet of the water filter to the plumbing of the house. The control valve must not be submitted to temperatures above 43°C (110°F). When sweat fittings are used, to avoid damaging the control valve, solder the threaded copper adapters to the copper pipe and then, using Teflon tape, screw the assembly into the bypass valve.
Do not use pipe thread compound as it may attack the material in the valve body.
4. Apply Teflon Tape and Orings to the fittings
5. Connect Filter to the house plumbing. Any solder joints near the valve must be done before connecting any piping to the valve. Always leave at least 6" (152 mm) between the valve and joints when soldering pipes that are connected to the valve. Failure to do this could cause damage to the valve.
6. **Drain Line connection:** Using Teflon tape, screw the 1/2" hose barb and attach oring into the drain port in the valve. Attach 1/2" drain hose (Supplied with some models and brands) to the hose barb and tighten securely with a hose clamp (Supplied with some models and brands). Run the drain line to a floor drain or a laundry drain. Complete any necessary plumbing.
7. Using the Allen Key (included), place the unit in the bypass position. Slowly turn on the main water supply. At the nearest cold treated water tap nearby remove the faucet screen, open the faucet and let water run a few minutes or until the system is free of any air or foreign material resulting from the plumbing work.
8. Make sure there are no leaks in the plumbing system before proceeding. Close the water tap when water runs clean.
9. Open the brine tank / cabinet salt lid and add water until there is approximately 3" (75 mm) of water in the tank. Do not add salt to the brine tank at this time.

NOTE

If the plumbing system is used as the ground leg of the electric supply, continuity should be maintained by installing ground straps around any nonconductive plastic piping used in installation.

NOTE

Before starting installation, read page 16, Plumbing System Clean-Up, for instructions on some procedures that may need to be performed first.

WATER CONDITIONER INSTALLATION

Connect Conditioner to the House Plumbing Any solder joints near the valve must be done before connecting any piping to the valve. Always leave at least 6" (152 mm) between the valve and joints when soldering pipes that are connected to the valve. Failure to do this could cause damage to the valve.

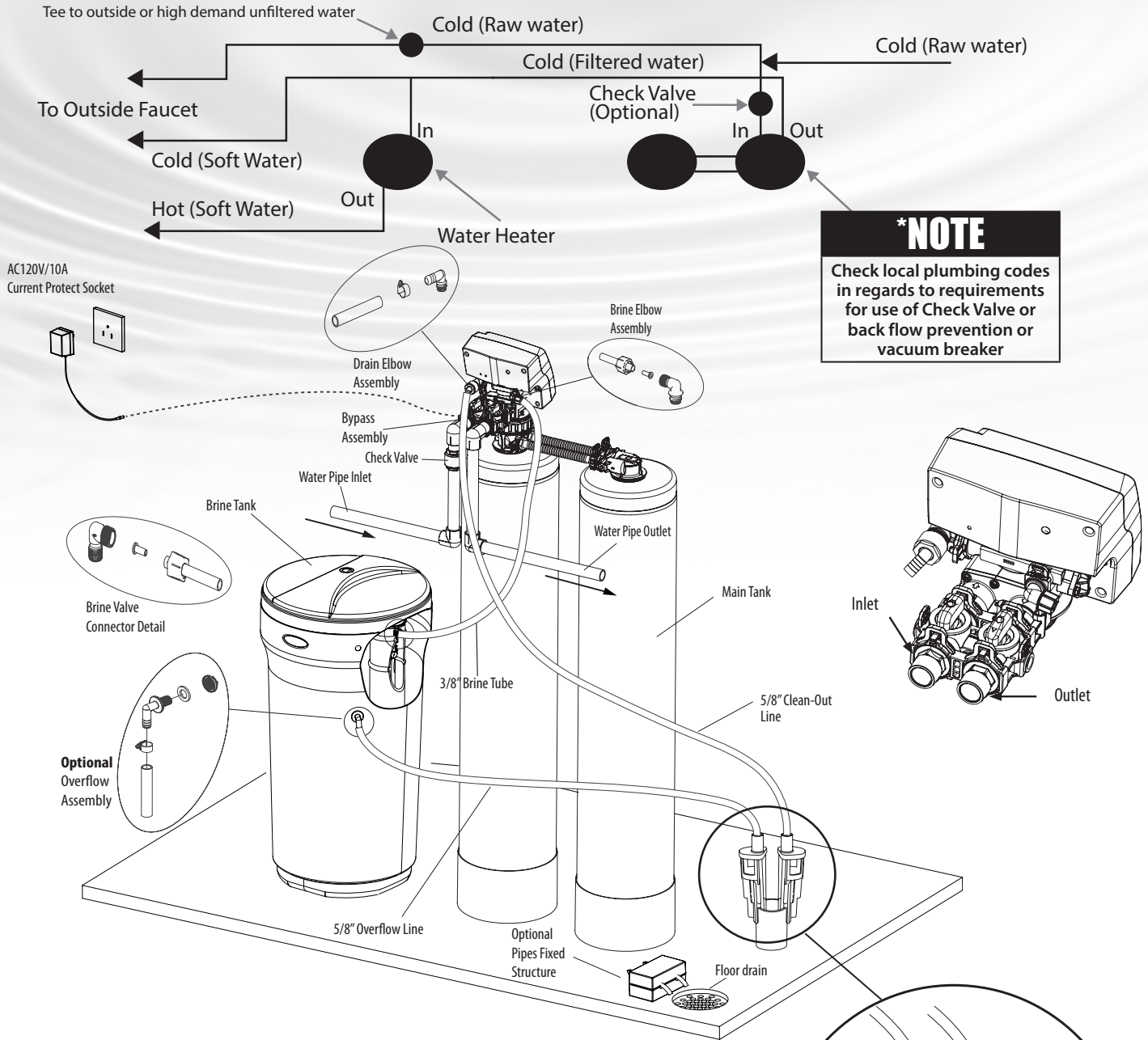

***NOTE**
Check local plumbing codes in regards to requirements for use of Check Valve or back flow prevention or vacuum breaker

NOTE
Waste connections or drain outlet shall be designed and constructed to provide for connection to the sanitary waste system through an air-gap of 2 pipe diameters or 1 inch (22 mm) whichever is larger.

CAUTION!
Never insert drain line directly into a drain, sewer line, or trap. Always allow an air gap between the drain line and the wastewater to prevent the possibility of sewage being back-siphoned into the conditioner.

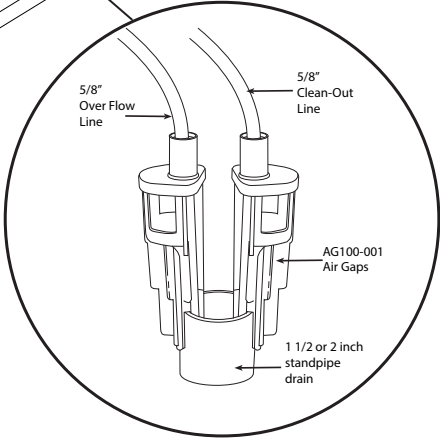

STARTUP INSTRUCTIONS

1. Connect the Transformer to the Valve

Plug the 12-volt transformer into a 120 VAC 60 Hz outlet.

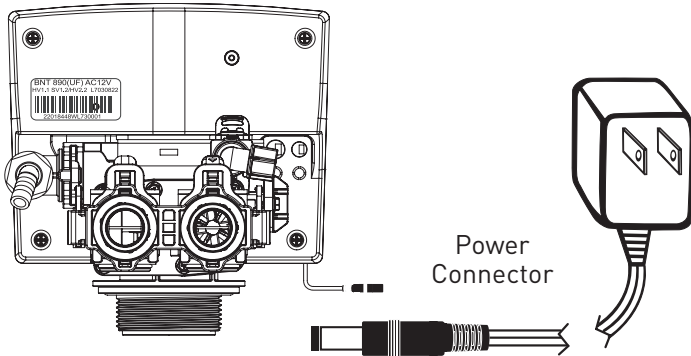

2. Screen Display

When power is supplied to the control the screen will display "INITIALIZING WAIT PLEASE"

while it finds the service position.

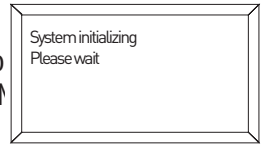

Familiarize with Button Configuration:

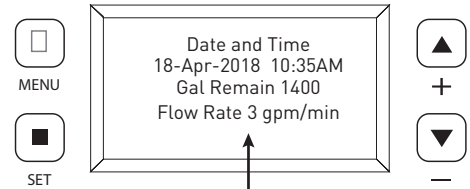

The controller will show the following on the screen: Time, Date and Gallons Remaining for Regeneration

Key Pad Configuration

MENU This function enters the basic set up information required at the time of installation.

SET This function accepts the values if changed and advance to the next page in the menu

These buttons increase or decrease the value of the settings while in the programming mode.

3. Add Water to Brine Tank

Open the brine tank Sodium Chloride lid and add water as per the info below. Do not add Sodium Chloride to the brine tank at this time.

BRINE TANK MODEL – Water to be Added at the Time of Installation:

BTR-100 (18.1" x 34.7") - 2.5 US Gallons

4. Manually Regenerate the Valve

If screen is locked, press **MENU** Key for 5 seconds to unlock

Manually Regenerate the Valve and move it to backwash position. Press **MENU** Key and Scroll down using **Up** and **Down** Arrow buttons to **Manual Regen.** Press **SET** Select **Regen Now**

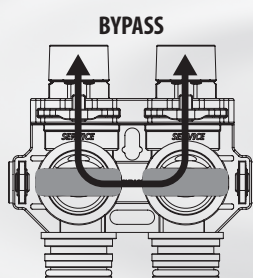
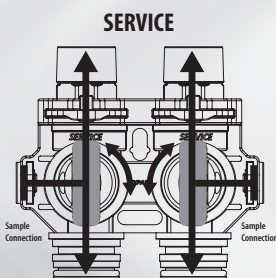
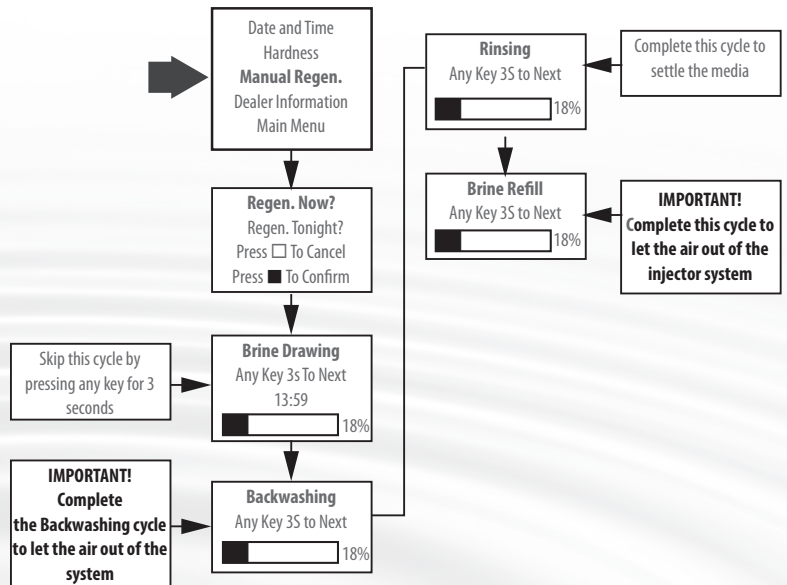

STARTUP INSTRUCTIONS (CONTINUED)

4. Manually Regenerate the Valve (Continued)

NOTE** All units are factory programmed for the correct size and regeneration cycle alteration should only be done by a factory trained technician or after consultation with one of our technical representatives if you have any questions please contact:

Evince® Direct Phone Number: 951.734.7400

Service Related Matters: customerservice@Evincewater.com

General questions: info@Evincewater.com

4a. Open the inlet on the bypass valve slightly and very slowly allow water to enter the unit. (If the water enters too quickly it will push the media or carbon up into the control valve and get plugged).

Once the unit has filled sufficiently that water is at least equal to the height of the top of the media shut down the water for 15 – 20 minutes for the carbon to soak. Unplug the power cable. After the carbon has soaked for the recommended time continue.

4b. Open the inlet on the bypass valve slowly and allow water to enter the unit. (The outlet of the bypass should remain closed to prevent any fines or debris from entering the plumbing system. Allow all air to escape from the unit before turning the water on fully then allow water to run to drain for 3-4 minutes, or until the water at the drain appears to be clear of any fines).

5. Plug in the valve and the valve will automatically advance to the SERVICE position. Open the outlet valve on the bypass, then slowly open the nearest treated water faucet and allow the water to run until clear, close the tap and replace the faucet screen.

6. The Valve is already programmed by the factory. Please continue with set up of current time and hardness.

PROGRAMMING THE CONDITIONER

Press "MENU" Key and Select "Date and Time" using "SET" Button and set for setting the regeneration time, Press "MENU" Key and Select Main Menu till you hear a beep and select Regen time.

SET UP CURRENT TIME OF THE DAY AND HARDNESS:

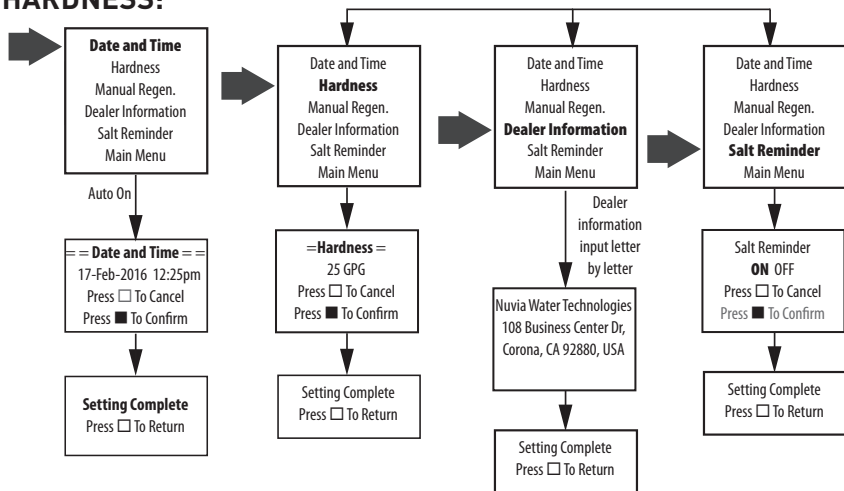

SET UP REGENERATION TIME:

Press Set Key till you hear "Beep"

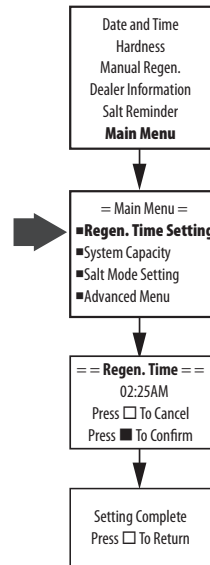

5. ADD SODIUM TO THE BRINE TANK

Put 88 lbs of crystal water refiner sodium in the brine tank. The unit will automatically fill the water to the correct level when it regenerates.

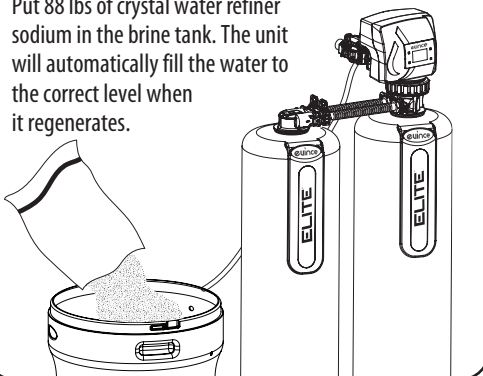

**START UP AND PROGRAMMING COMPLETE.
UNIT IS NOW OPERATIONAL.**

DURING REGENERATION

Automatic Water Bypass

The regeneration cycle lasts approximately 1.5 hours to 3.0 hours depending on the specific model, after which treated water service will be restored. During regeneration, untreated water is automatically bypassed for use in the household. Hot water should be used as little as possible during this time to prevent hard water from filling the water heater.

IMPORTANT: Automatic regeneration is set for sometime during the night and manual regenerations should be performed when little or no water will be used in the household.

Manual Water Bypass

In case of an emergency or when performing maintenance, you can isolate your water conditioner from the water supply using the bypass valve located at the back of the control. In normal operation the bypass is open with the ON/OFF knobs in line with the INLET and OUTLET pipes. To isolate the conditioner, simply rotate the knobs clockwise (as indicated by the word BYPASS and arrow) until they lock. You can use your water related fixtures and appliances as the watersupply is bypassing the conditioner. However, the water you use will be hard. To resume treated service, open the bypass valve by rotating the knobs counterclockwise. **Please make sure bypass knobs are completely open otherwise the unconditioned water could bypass through the valve.**

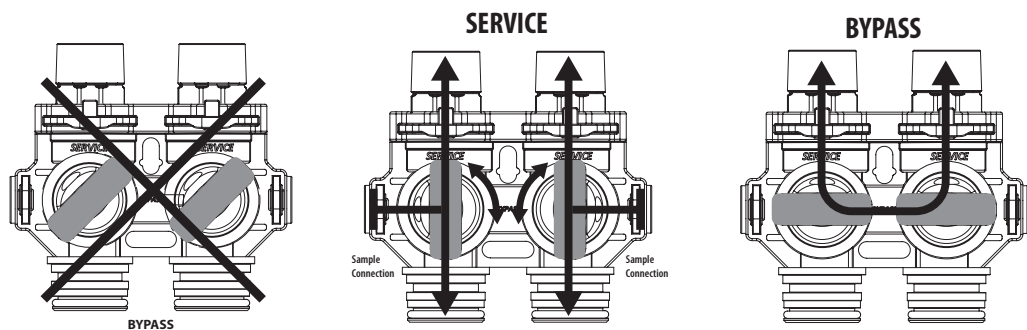

New Sounds

You may notice new sounds as your water conditioner operates. The regeneration cycle lasts approximately 1.5 hours to 3.0 hours depending on the specific model. During this time, you will be able to hear water running intermittently to the drain, depending on proximity of the unit to sleeping area and time of regeneration.

PLUMBING SYSTEM CLEAN-UP

The following procedures are guidelines only but have proven successful in most instances. Under no circumstances should any procedure outlined below be followed if contrary to the appliance manufacturer's instructions. Should there be any questions concerning the advisability of performing a procedure, it is strongly recommended the manufacturer's authorized service outlet be consulted prior to performing the procedure.

Water Heater

If the water heater has been exposed to both iron and hardness for a long period of time, replacement of the heater tank maybe the only practical solution to prevent continued staining originating from this source. After completing the installation of the conditioner, clean the water heater by following these instructions:

1. Shut off energy supply to water heater and close heater inlet water valve.
2. Drain hot water tank completely. Open inlet water valve allowing heater tank to be refilled with iron-free water. Continue flushing until water runs clear to drain.
3. If, after approximately 30 minutes flushing, water does NOT clear, terminate flushing operation. Refill hot water heater with water and pour approximately 1/2 gallon of household bleach into top of heater tank. Allow bleach solution to stand in tank for 20 to 30 minutes. Flush tank

Dishwasher

Consult owners' handbook and follow manufacturer's instructions.

Toilet Flush Tanks

Prior to commencing installation of the conditioner system, pour 4 to 6 ounces of resin mineral cleaner Pro-Rust Out or or other suitable cleaner such as CLR that contains a mild acid into flush tanks and bowls and let stand. When installation is completed, flush toilets several times with conditioned water. If stains or deposits return check that lines are connected to treated water. Repeat procedure until clear. again until water is clear at drain. Turn energy supply on.

NOTE

If water does not clear in approximately 10 minutes, water heater should probably be replaced.

MAINTENANCE INSTRUCTIONS AND SCHEDULE

System Check List

NOTE All units are factory programmed for the correct size and regeneration cycle alteration should only be done by a factory trained technician or after consultation with one of our technical representatives if you have any questions please call: 951.734.7400**

4a. Open the inlet on the bypass valve slightly and very slowly allow water to enter the unit. (If the water enters too quickly it will push the media up into the control valve and get plugged).

Once the unit has filled sufficiently that water is at least equal to the height of the top of the media shut down the water for 15 – 20 minutes for the media bed to soak. Unplug the power cable. After the media bed has soaked for the recommended time continue.

4b. Open the inlet on the bypass valve slowly and allow water to enter the unit. (The outlet of the bypass should remain closed to prevent any fines or debris from entering the plumbing system. Allow all air to escape from the unit before turning the water on fully then allow water to run to drain for 3-4 minutes, or until the water at the drain appears to be clear of any fines.

4c. Plug in the valve. Allow the valve to continue its cycles until complete and back in service

4d. The Valve is already programmed from factory. Please set up date and time of day and feedwater iron as shown below:

Service Schedule

- The seals and spacers along with the piston assembly should be inspected/cleaned or replaced every year depending on the inlet water quality and water usage on clean municipal supplies every 2 - 3 years should be sufficient but the first check should be done after 1 year. See inspection and replacement of Piston assembly and seal and spacer kit, page 26.
- The injectors should be cleaned/inspected or replaced every year depending on the water quality and use. See Clean Injector Assembly, page 27.

Maintenance of your new water conditioner requires very little time or effort but it is essential. Regular maintenance will ensure many years of efficient and trouble free operation.

FAILURE TO FOLLOW BASIC MAINTENANCE SCHEDULE WILL RESULT IN THE UNIT FAILING TO OPERATE PROPERLY AND VOID YOUR WARRANTY.

Bridging

Humidity or the wrong type of Sodium Chloride may create a cavity between the water and the Sodium Chloride. This action, known as “bridging”, prevents the brine solution from being made, leading to your water supply being hard. If you suspect Sodium Chloride bridging, carefully pound on the outside of the plastic brine tank or pour some warm water over the Sodium Chloride to break up the bridge. This should always be followed up by allowing the unit to use up any remaining Sodium Chloride and then thoroughly cleaning out the brine tank. Allow four hours to produce a brine solution, then manually regenerate the conditioner.

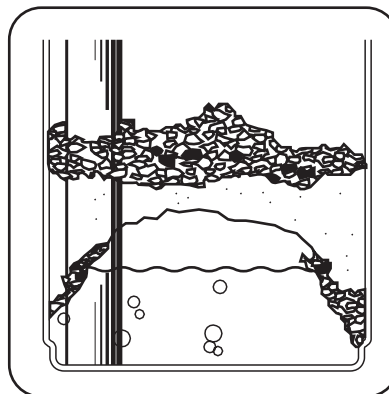

CAUTION!

Liquid brine will irritate eyes, skin and open wounds - gently wash exposed area with fresh water. Keep children away from your water conditioner.

Cleaning of your Brine / Sodium Chloride tank

Sodium Chloride tanks will build up sludge (undissolved Sodium Chloride) in the bottom of them that will continue to increase as time goes by. Every 2 - 3 years the Sodium Chloride tank should be cleaned out completely and re started using the original start up instructions.

CAUTION!

Never subject your conditioner to freezing, vacuum or to temperatures above 43°C (110°F).

MAINTENANCE INSTRUCTIONS AND SCHEDULE

Checking the Sodium Chloride Level

Check the Sodium Chloride level monthly. Remove the lid from the cabinet or brine tank, make sure Sodium Chloride level is always above the brine level.

Add Sodium Chloride to the Brine Tank

Put 40 kgs of crystal water conditioner Sodium Chloride in the brine tank. The unit will automatically fill the water to the correct level when it regenerates. Use only clean Sodium Chloride labeled for water conditioner use, such as crystal, pellet, nugget, button or solar. The use of rock Sodium Chloride is discouraged because it contains insoluble silt and sand which build up in the brine tank and can cause problems with the system's operation. Add the Sodium Chloride directly to the tank, filling no higher than the top of the brine well.

NOTE :THE WATER LEVEL SHOULD BE BELOW THE Sodium Chloride LEVEL ALL THE TIME

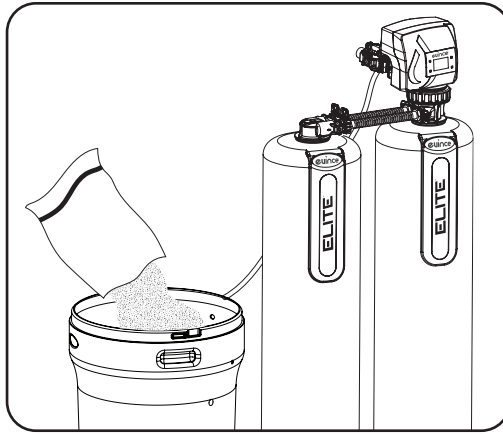
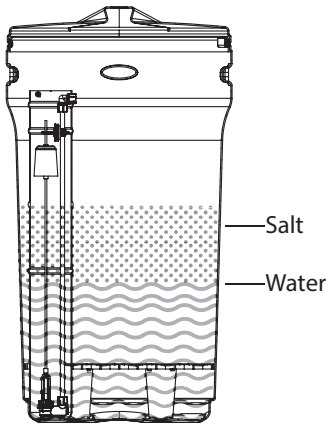

! CAUTION!

Incorrect start up, water above the Sodium Chloride level, (not enough Sodium Chloride in tank) will both effect the units capacity and result in hardness slippage. Should either of these situations happen or the unit fails to regenerate for any other reason please first correct the problem. Then regenerate the unit manually 2 times in a row to restore the reserve capacity and bring the media bed back up to specification.

IMPORTANT WARRANTY AND MAINTENANCE INFORMATION

Please have the information below filled out and available when calling in for parts or warranty:

Model number:
Serial number:
Valve Serial number:
Date installed:

Additional notes:

Care of Your Conditioner

To retain the attractive appearance of your new water conditioner, clean occasionally with a mild soap solution. Do not use abrasive cleaners, ammonia or solvents. Never subject your conditioner to freezing or to temperatures above 43°C (110°F).

Servicing Components

- The injector assembly should be cleaned or replaced every year depending on the inlet water quality and water usage.
- The seals and spacer should be inspected/cleaned or replaced every year depending on the inlet water quality and water usage.

Please refer to the servicing section of this manual for step by step procedure.

Not following the above will void all warranty on the control valve.

Resin Cleaner

An approved resin cleaner **MUST** be used on a regular basis if your water supply contains iron. The amount of resin cleaner and frequency of use is determined by the quantity of iron in your water (consult your local representative or follow the directions on the resin cleaner package).

RES-UP® FEEDER INSTALLATION INSTRUCTIONS (OPTIONAL)

Res-Up Feeders attach to your brine tank and automatically dispense the Res-Up cleaner into the brine solution where it cleans the resin during the regeneration cycle.

The feeder hooks onto the tube inside your brine tank and you just pour some chemical in it and your water conditioner should last significantly longer. A res-up feeder is essential if your raw water contains measurable amounts of iron.

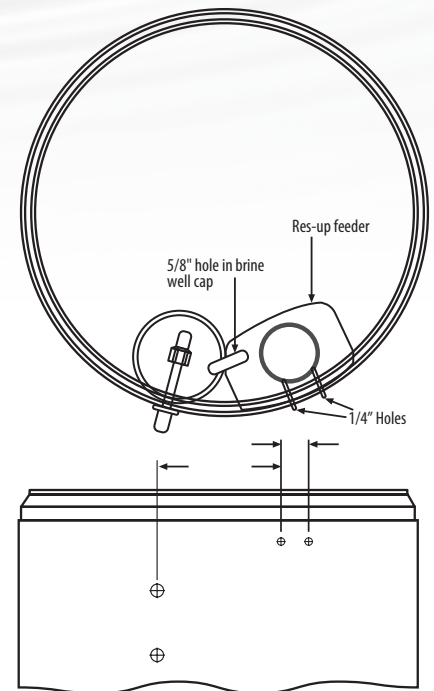

Res-up Feeder Bottle (Chemical sold Separately)
The 12 cc feeder (Part # 33010) is for conditioners up to 64,000 grains (2 ft ³ of resin).
The 30 cc feeder (Part # 33018) is for larger conditioners over 64,000 grains.
Pro-Res Care Chemicals
Item #45147 Pro-ResCare - Gallon
Item #45148 Pro-ResCare - Quart

Install Resup Feeder

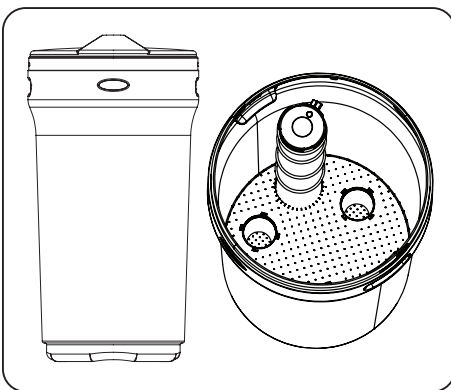

1. Install the grid and brine well inside the tank.

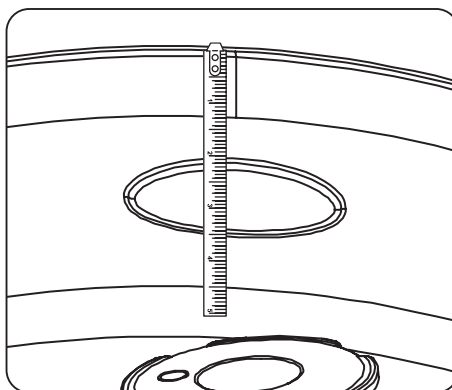

2. Measure 2 inches from the top of the tank beside the oblong molding.

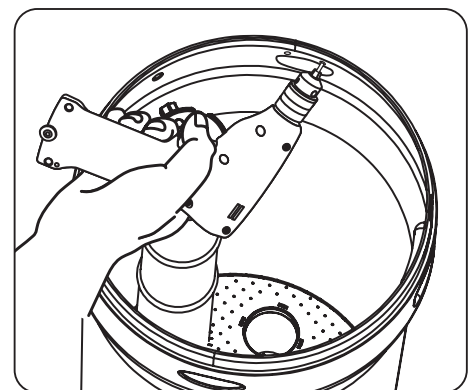

3. Mark the location of the holder and drill.

Res-Up® Feeder Installation Instructions (Optional)

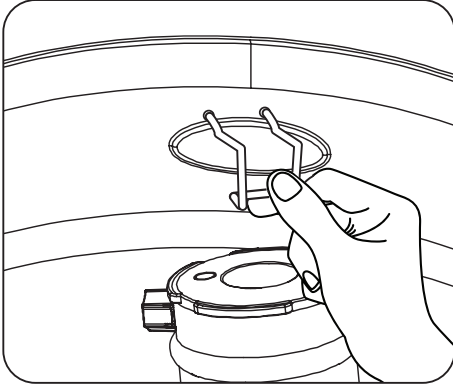

4. Install the holder and the Res Care Solution

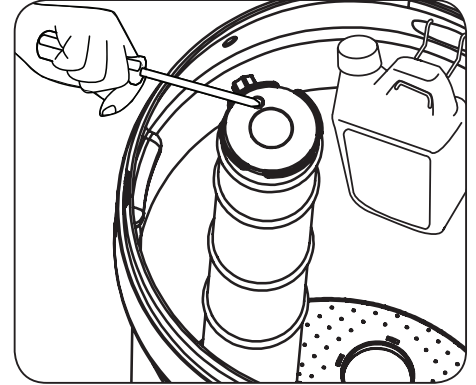
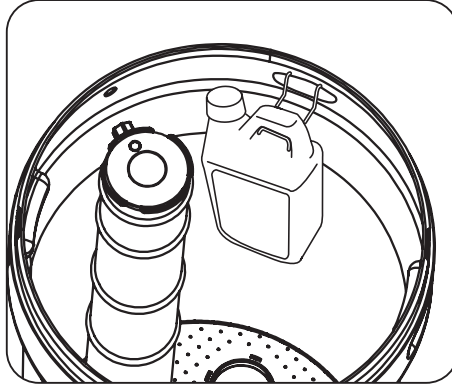

5. Take off the small hole cover on the Brine Well lid.

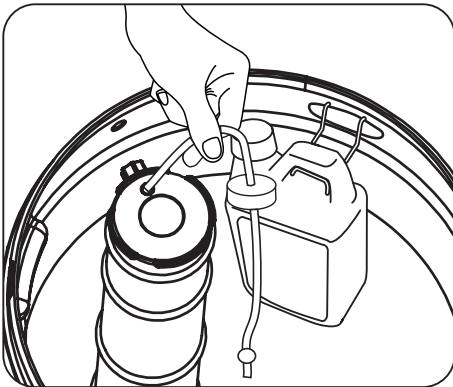

6. Take off the cover of the Res care bottle . Insert the wick, making sure it touches the bottom of the bottle. Insert the other end of the tube completely into the hole in the brine well cap. Automatic feeding will start in a few hours.

SERVICING EVINCE ELITE VALVE

Before Servicing

1. Turn off water supply to conditioner :
 - a. If the conditioner installation has a 3 valve bypass system first open the valve in the bypass line, then close the valves at the conditioner inlet & outlet.
 - b. If the conditioner has an integral bypass valve, put it in the bypass position.
 - c. If there is only a shut-off valve near the conditioner inlet, close it.
2. Relieve water pressure in the conditioner by stepping the control into the backwash position momentarily. Return the control to the In Service position.
3. Unplug Electrical Cord from outlet.
4. Disconnect drain line connection.



WARNING!

**ELECTRICAL SHOCK
HAZARD! UNPLUG THE UNIT
BEFORE REMOVING THE
COVER OR ACCESSING ANY
INTERNAL CONTROL PARTS**



CAUTION!

**Disassembly while under
pressure can result in flooding.
Always follow these steps prior
to servicing the valve.**

MASTER PROGRAMMING

Below is how the settings are set at factory:

PRESS '+' AND '-' FOR 8 SECONDS							PRESS MENU KEY AND SCROLL TO 'MAIN MENU'. THEN PRESS 'SET' TILL IT BEEPS. SCROLL TO ADVANCED MENU						
MODELS	LANGUAGE	REGION	VALVE	METER RATIO	Sodium VS EFFICIENCY	AUTO CALCULATION	Cycle Delay	RESIN VOLUME	REFILL RATE	REGEN MODE	BW/rinse OVERRIDE	bw/RINSE OVERRIDE	EMERGENCY REGEN.
EV-ELT-948-1.0	ENGLISH	US GALLONS	DYNAMIC	Turbine L	3lbs-3400 6lbs-2650 12lbs-2000	ON	DEFAULT	1.0 CF	0.2	METER DELAY	ON - 10	00	OFF
EV-ELT-1054-1.0	ENGLISH	US GALLONS	DYNAMIC	Turbine L	3lbs-3400 6lbs-2650 12lbs-2000	ON	DEFAULT	1.5 CF	0.2	METER DELAY	ON - 10	00	OFF
EV-ELT-1252-1.0	ENGLISH	US GALLONS	DYNAMIC	Turbine L	3lbs-3400 6lbs-2650 12lbs-2000	ON	DEFAULT	2.0 CF	0.2	METER DELAY	ON - 10	00	OFF
EV-ELT-1354-1.0	ENGLISH	US GALLONS	DYNAMIC	Turbine L	3lbs-3400 6lbs-2650 12lbs-2000	ON	DEFAULT	2.5 CF	0.2	METER DELAY	ON - 10	00	OFF

PRESS MENU KEY AND SCROLL TO 'MAIN MENU'. THEN PRESS 'SET' TILL IT BEEPS. SCROLL TO ADVANCED MENU										
BRINE RINSE	BACK WASH	RINSE	BRINE REFILL	AUXILIARY OUTPUT	SERVICE SETTINGS	BACKLIGHT SETTINGS	HISTORY VALUES	SODIUM REMINDER - SODIUM USAGE	ALARM ON TIME	SODIUM QUANTITY
DEFAULT	DEFAULT	15	DEFAULT	DONT TOUCH	OFF	Energy Save	Reset history	DEFAULT	5:00PM-7:00PM	80 lbs
DEFAULT	DEFAULT	15	DEFAULT	DONT TOUCH	OFF	Energy Save	Reset history	DEFAULT	5:00PM-7:00PM	80 lbs
DEFAULT	DEFAULT	15	DEFAULT	DONT TOUCH	OFF	Energy Save	Reset history	DEFAULT	5:00PM-7:00PM	80 lbs
DEFAULT	DEFAULT	15	DEFAULT	DONT TOUCH	OFF	Energy Save	Reset history	DEFAULT	5:00PM-7:00PM	80 lbs

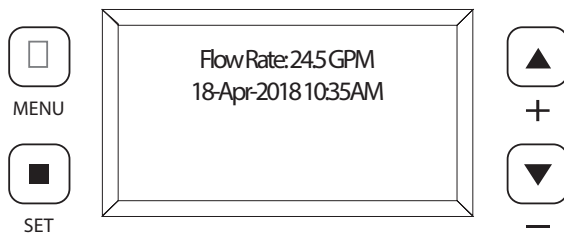

PRESS MENU KEY AND SCROLL TO 'MAIN MENU'. THEN PRESS 'SET' TILL IT BEEPS					VALVE SETTINGS					
REGEN TIME	SYSTEM CAPACITY	SODIUM MODE SETTING	BRINE PREFILL SET	PREFILL	Injector	Injector Color	BLFC Washer	DLFC Washer	DLFC Washer Code	
2:00AM	DEFAULT	STANDARD	ON	70%	#0000	Black	0.2 GPM	4.00	35	
2:00AM	DEFAULT	STANDARD	ON	70%	#0000	Black	0.2 GPM	5.0	45	
2:00AM	DEFAULT	STANDARD	ON	70%	#00	Purple	0.2 GPM	7.00	1	
2:00AM	DEFAULT	STANDARD	ON	70%	#00	Purple	0.2 GPM	7.0	1	



Key Pad Configuration:

 **MENU** - This function is to enter the basic set up information required at the time of installation.

 **SET/REGEN** - This function is to accept the values if changed and advance to the next page in the menu.

  **UP/DOWN** - These buttons are used to increase or decrease the value of the settings while in the programming mode.

Step A - Region Setting

Press + and —. Hold until you hear a beep (8 seconds).

Press + or — to choose menu option. Press SETTINGS to enter.

Press + or — to change option. Press SETTINGS to accept.

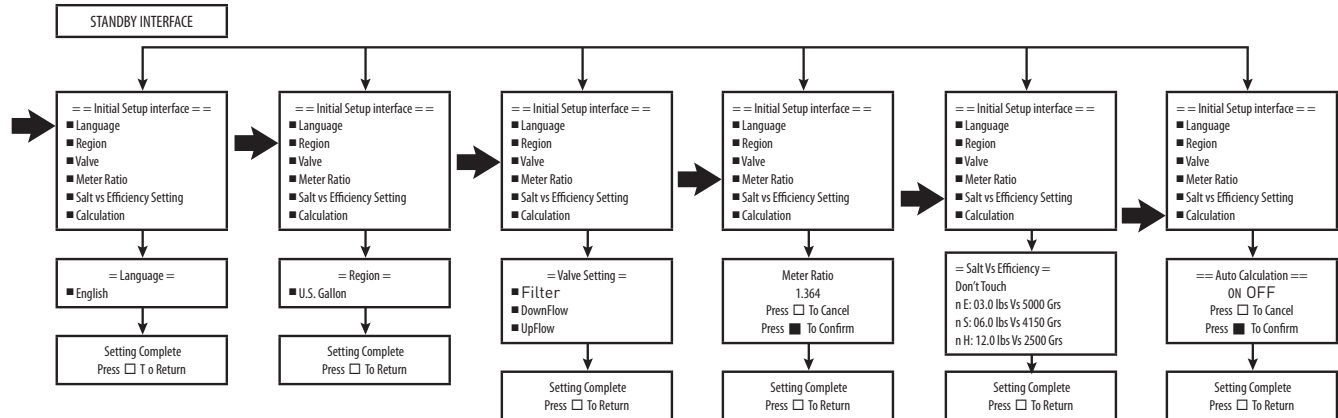

Step B - Advanced Menu

Press Menu key. Press — to advance to Advanced Menu

Press + or — to choose menu option. Press SET to enter

Press + or — to change option. Press SET to accept

Press Menu key. Press — to advance to Main Menu

Press SET or until you hear a beep.

Press — to advance to Advanced Menu

Press and hold SET 5 seconds or until you hear a beep.

Press + or — to choose menu option. Press SET to enter.

Press + or — to change option. Press SET to accept.

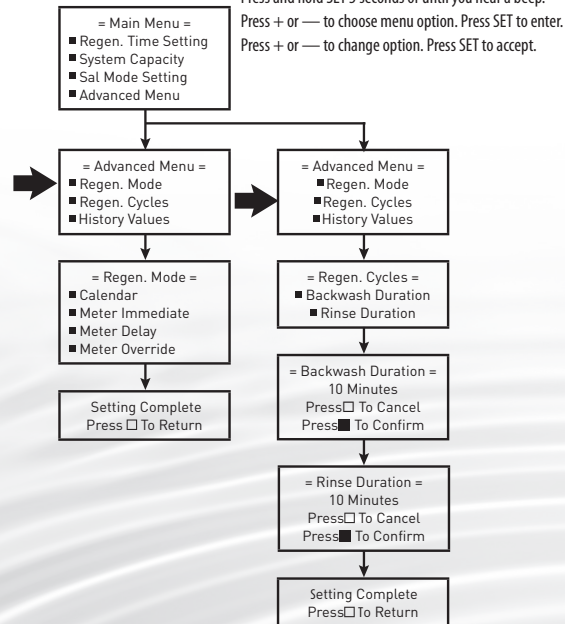

Step C - Main Menu

Press Menu key. Press — to advance to Advanced Menu

Press SET or until you hear a beep

Press + or — to choose menu option. Press SET to enter

Press + or — to change option. Press SET to accept

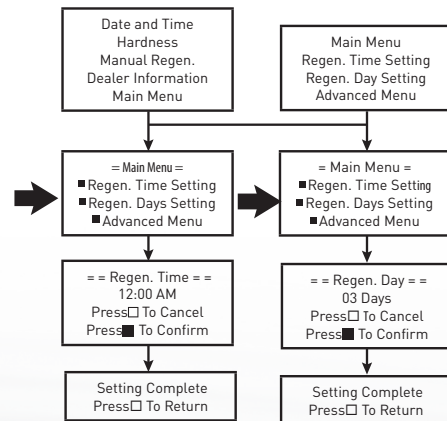

Step D - User Setting

Press Menu key

Press SET or until you hear a beep

Press + or — to choose menu option. Press SET to enter

Press + or — to change value. Press SET to accept

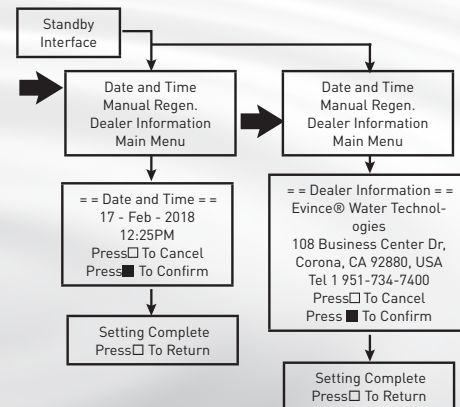

Diagnostic Screen

PRESS "MENU" KEY AND SCROLL TO "MAIN MENU". THEN PRESS "SET" TILL IT BEEPS. SCROLL TO ADVANCED MENU

Press **Menu** key and scroll to **Main Menu**. Then press **SET** till it beeps. Scroll to **Advanced Men**, Press and hold **SET** 5 seconds or until you hear a beep.

Press **Menu** key . Press - to advance to **Main Menu**. Press **SET** or until you hear a beep. Press - to advance to **Advanced Menu**
 Press and hold **SET** 5 seconds or until you hear a beep. Press - to advance to **History Values**. Press **SET** or until you hear a beep.
 Press or to choose menu option. Press **SET** to enter.
 Press or to change option. Press **SET** to accept.

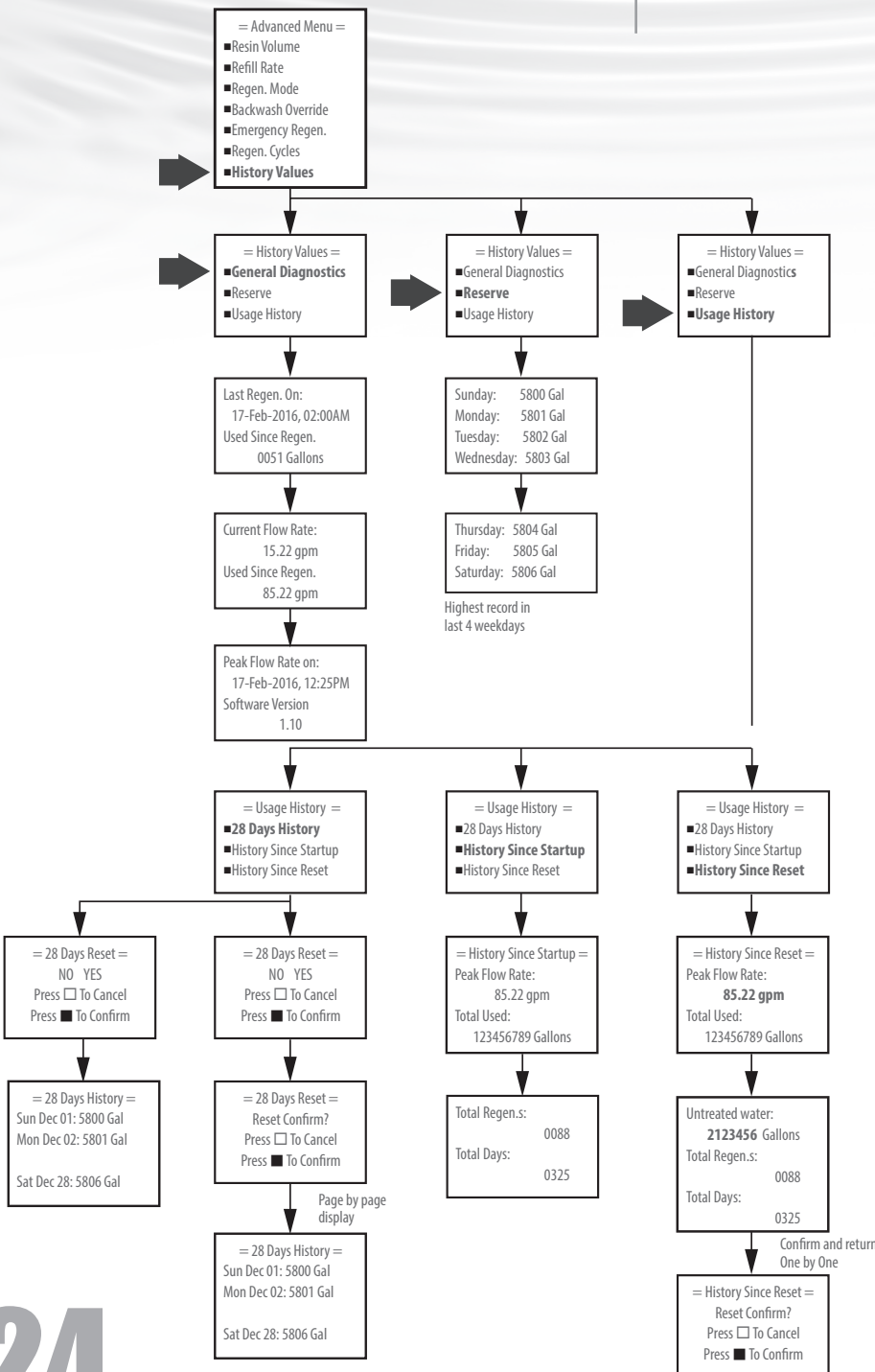

PARAMETER	DESCRIPTION
LAST REGEN ON	Date of last system regeneration.
USED SINCE REGEN	Volume used since last regeneration.
CURRENT FLOW RATE	The current system flow rate.
PEAK FLOW RATE	The peak or highest flow rate since last regeneration.
SOFTWARE VERSION	The software version programmed on the PCB.
RESERVE	The calculated reserve for each day based on the highest days usage over the past 4 weeks.
28 DAYS HISTORY	The volume used for each of the last 28 days.
USAGE HISTORY	The usage since system start up and from the last reset.
TOTAL USED	The total volume used.
TOTAL REGENS	The total quantity of regenerations.
TOTAL DAYS	The total days in operation.

REPLACE PISTON AND/OR BRINE VALVE ASSEMBLY

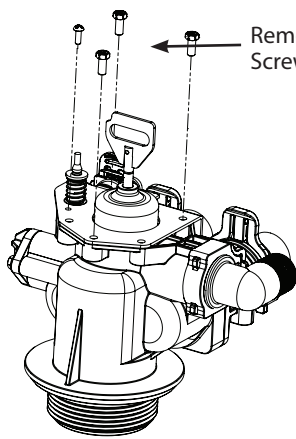

1. Follow steps 1 to 6 of timer /Powerhead replacement.
2. Remove four screws from the plate on the valve body.

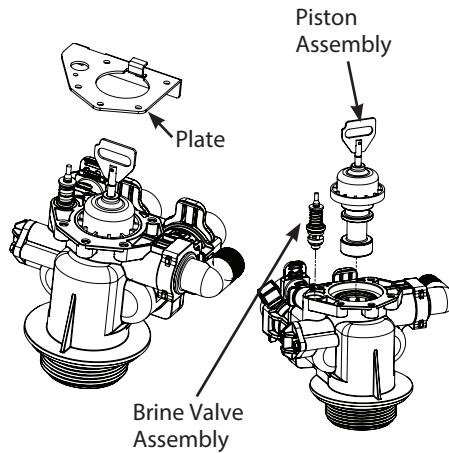

3. Remove the plate from the valve body and pull the Piston Assembly from the valve. The brine valve assembly can also be removed in this stage.
4. Remove the seal spacer assembly, grease it with silicone lubricant and put back in.

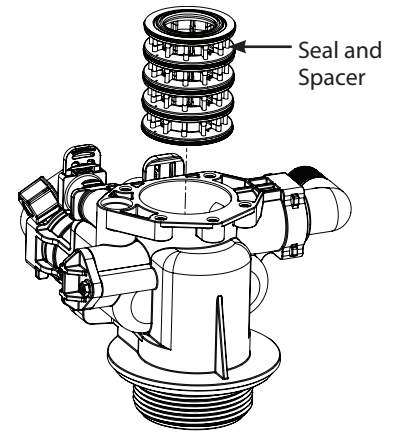

5. Replace piston assembly followed by timer assembly.
6. Replace the piston assembly and reverse following steps in this section

CLEAN INJECTOR ASSEMBLY

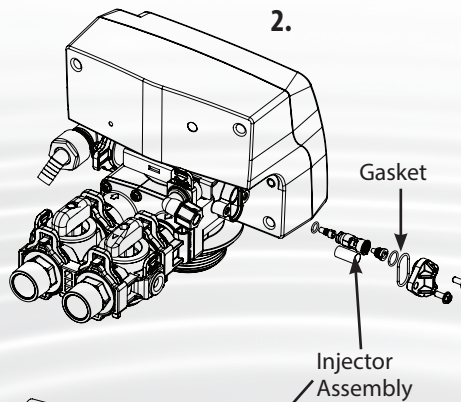
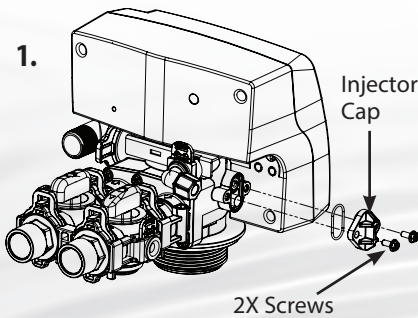

1. Remove the two screws from the injector cap
2. Pull the injector cap and gasket
3. Pull the injector assembly and screen
4. Replace/clean screen and injector assembly and put it back in the valve in appropriate location as shown
5. Put back the injector cap. Grease the injector assembly o-rings and injector cap gasket. Care should be taken to put all o-rings and gaskets in place and grease them so that they don't pinch

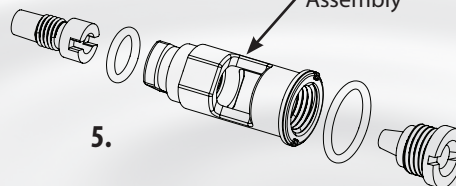
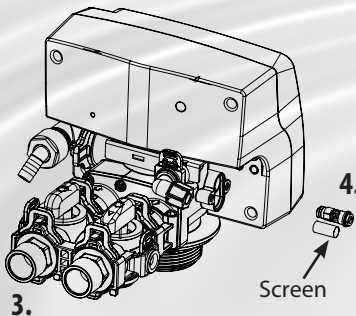

REPLACE TIMER

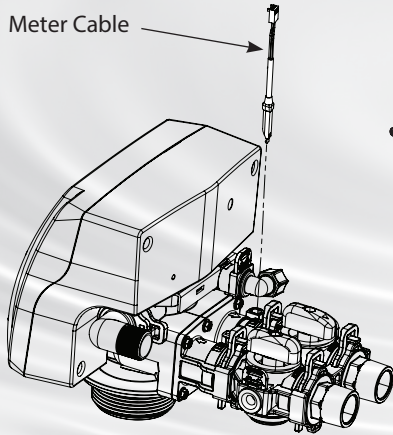

1. Disconnect the meter cable from the meter. (If flow meter is attached)

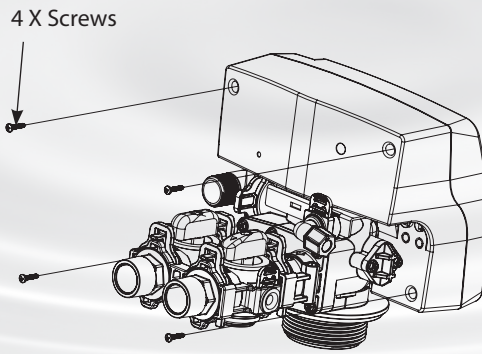

2. Remove four screws from the back of the valve cover

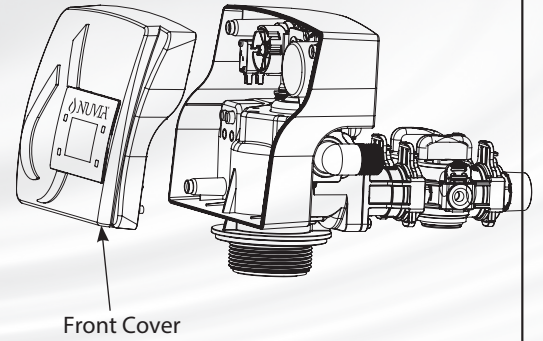

3. Remove the front cover of the valve.

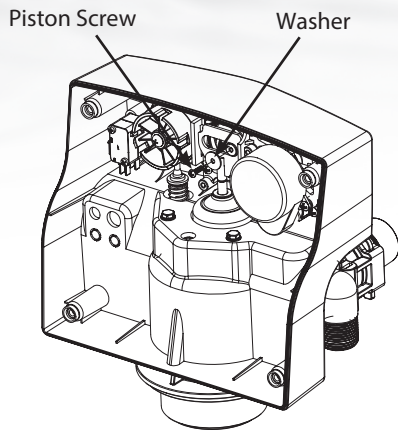

4. Remove the piston screw and washer from the piston rod.

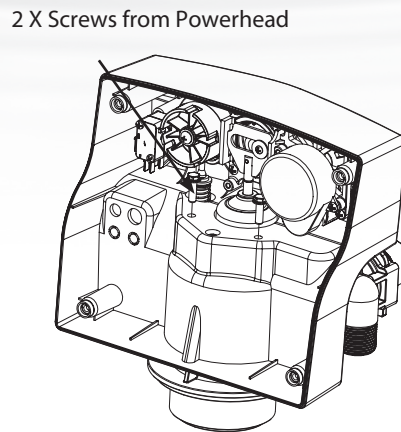

5. Remove the two screws from the powerhead as shown

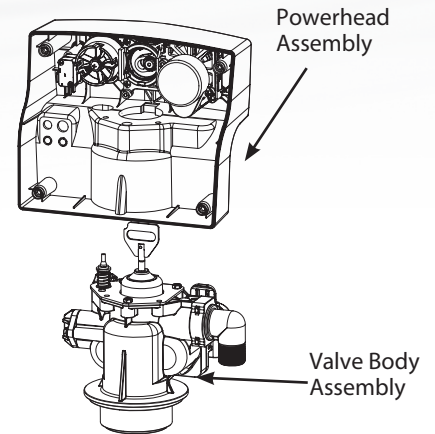

6. Lift the powerhead from the valve body assembly

7. Replace the powerhead by reverse following the steps in this section

REPLACE MOTOR

Cover 4X Screws

1. Remove Screws from the back of the valve and pull the cover

2. Remove all connections from the circuit board

3. Remove the two screws from the motor. Remove the motor and watch for the pin under the motor.

4. Replace the motor, connections and cover

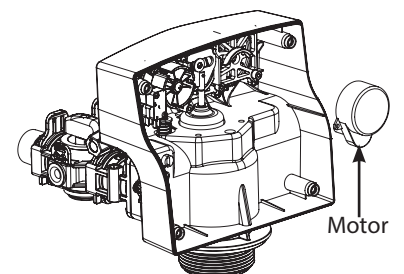
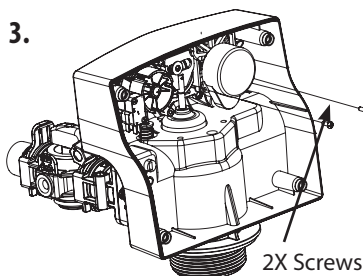
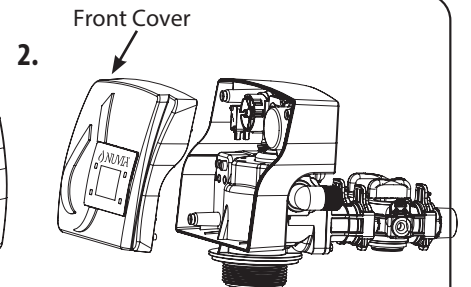
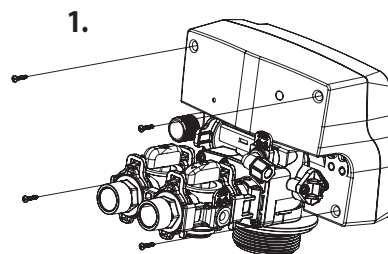

REPLACING THE BYPASS AND METER CABLE

Grey Meter Cable
60010267

60095101

Bypass comes with Meter
and Grey Meter Cable

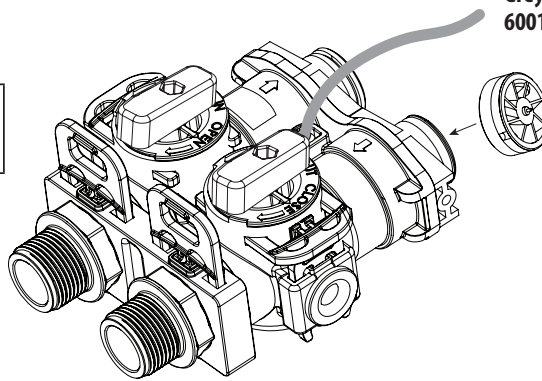

Step 1

Unplug the power from the wall socket.

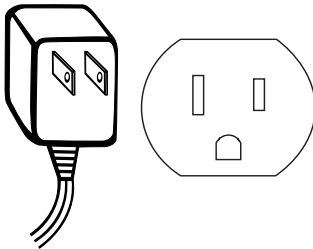

Step 2*

Remove 2 screws and clips from bypass.

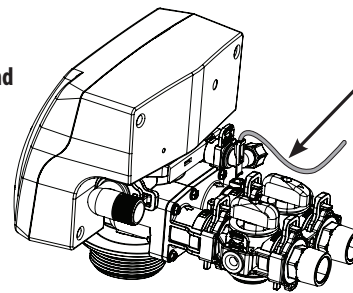

Disconnect the meter cable from the bypass.

*NOTE

Water to the household needs to be turned off and pressure relieved before Step 2

Step 3

Remove Cover.

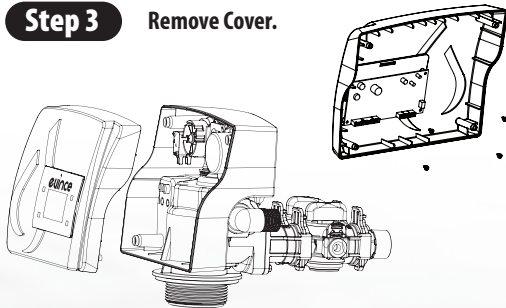

Step 4

Disconnect the cables from the front PCB display.

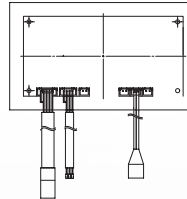

Step 5

Remove strain relief with pliers.

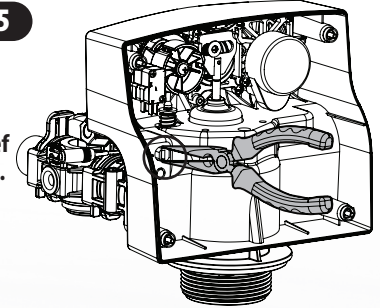

Step 6

Replace the old cable with the new Cable.

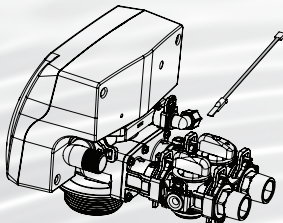

Step 7

Assemble the valve. Plug the power supply back into the wall socket.

*NOTE

For valve, meter ratio does not change

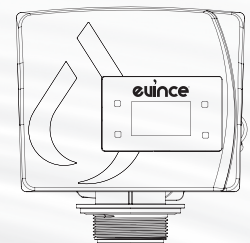

DISPLAY REPLACEMENT

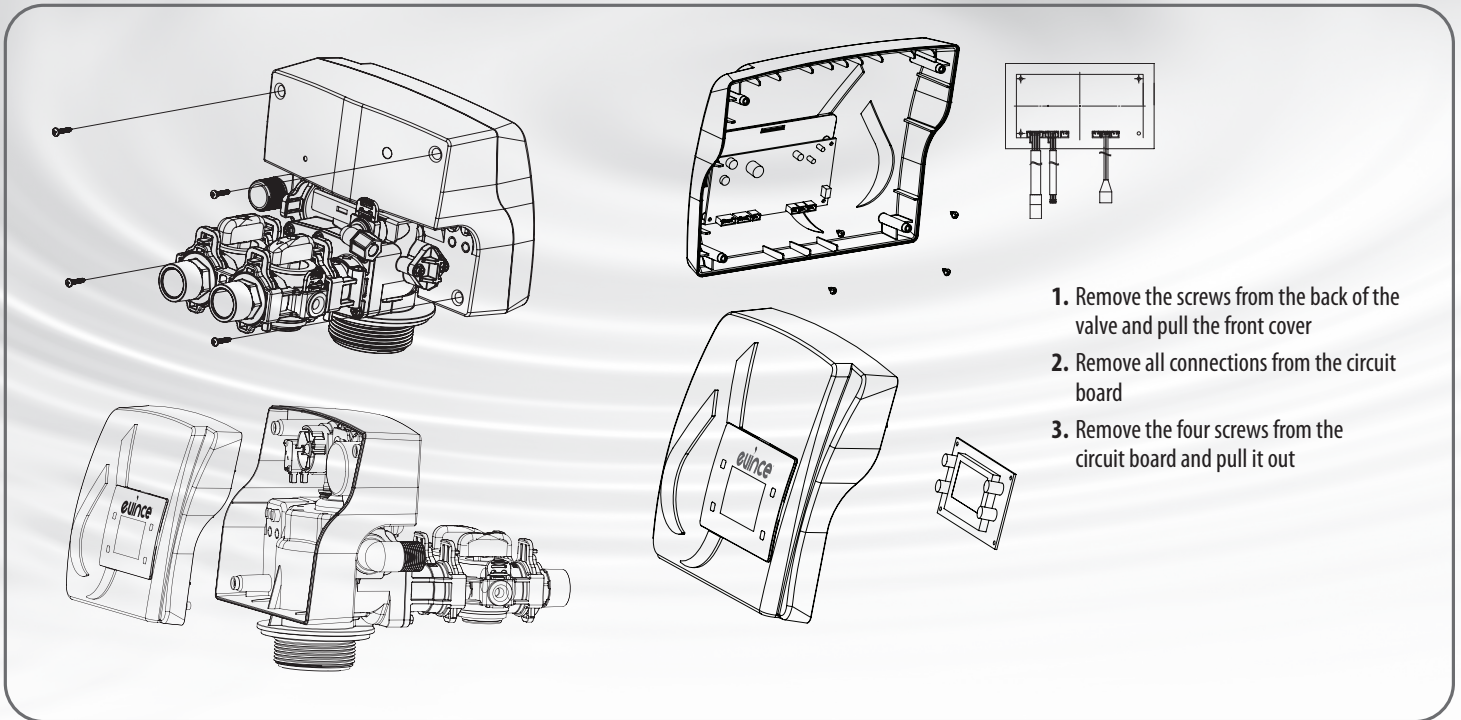

REPLACE MICROSWITCHES

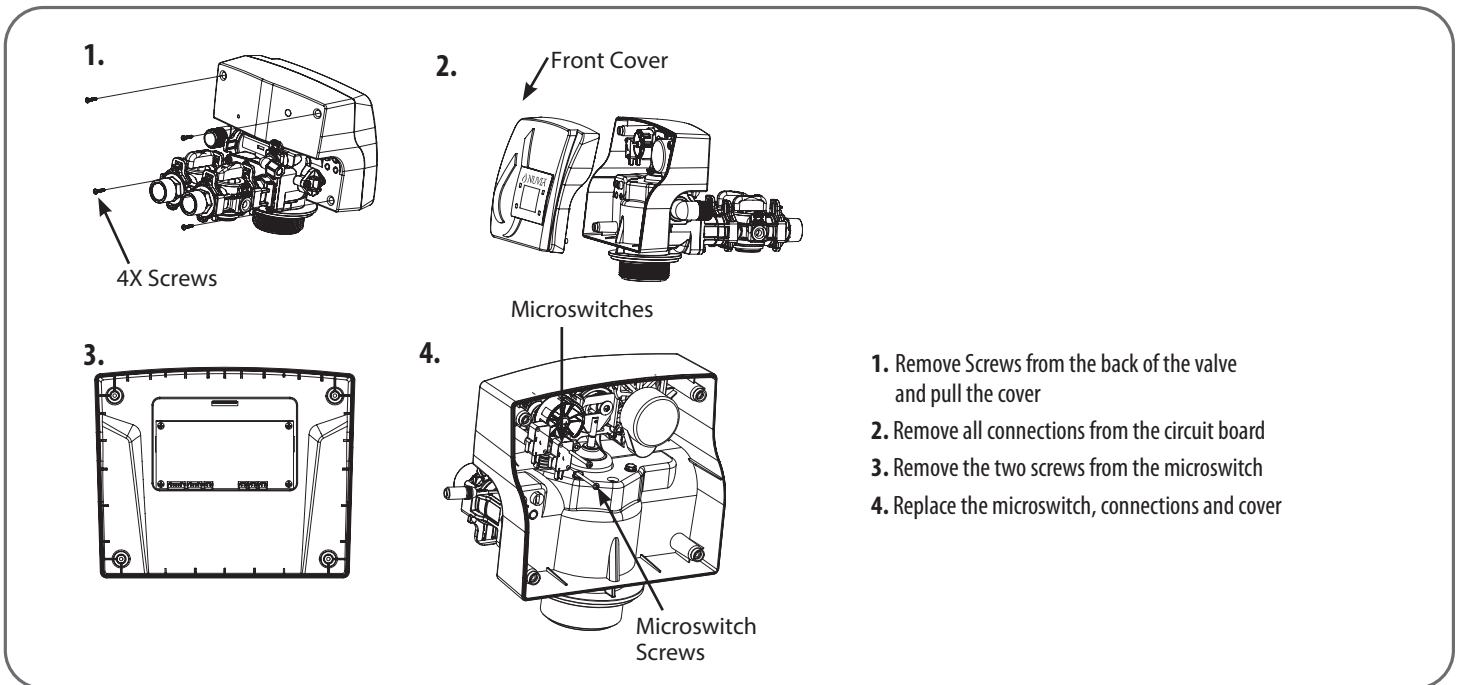

REPLACE DRAIN LINE FLOW CONTROL

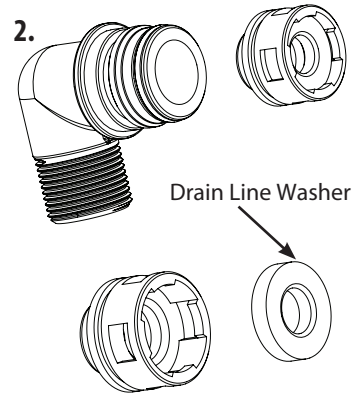
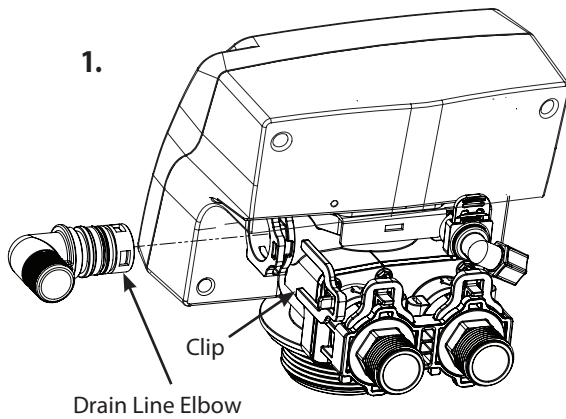

1. Pull the drain line clip and remove the drain line elbow and washer
2. Clean/replace drain line washer

REPLACE BRINE LINE FLOW CONTROL

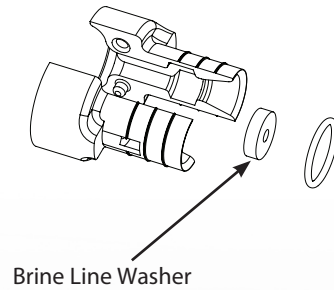
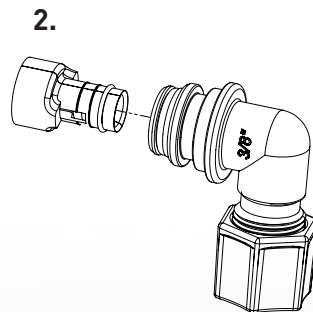
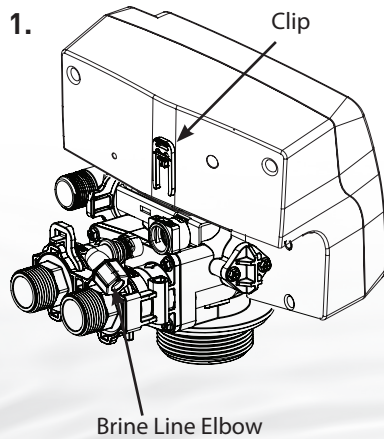

1. Pull the brine line clip and remove the brine line elbow and washer
2. Clean/replace brine line washer

AFTER SERVICING

1. Reconnect drain line
2. Return bypass or inlet valve to normal in service position. Water pressure will automatically build in the refiner
3. Check for leaks at all sealed areas. Check drain seal with the control in the backwash position
4. Plug electrical cord into outlet
5. Set Time of Day and cycle the control valve manually to assure proper function. Make sure control valve is returned to the In Service position

NOTE

Be sure to shut off any bypass line.

PARTS BREAKDOWN

Control Valve

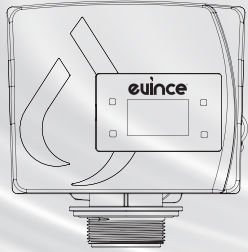

Straight Connector 1" - 60090003
Elbow Connector 1" - 60090026

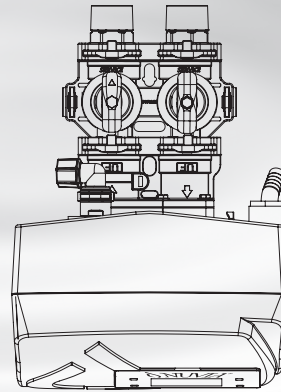
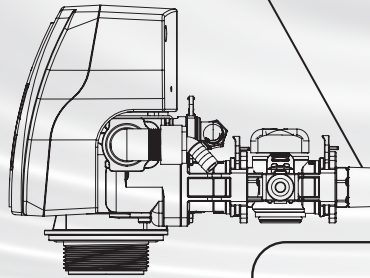

Part # 60010068

Part # 600100125

Part # 18280

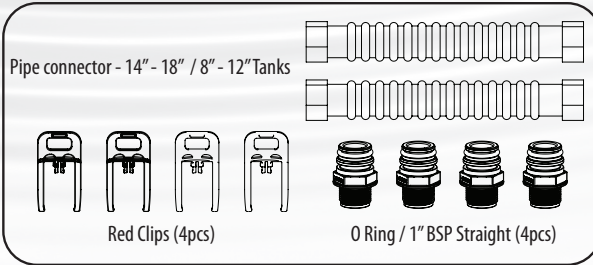
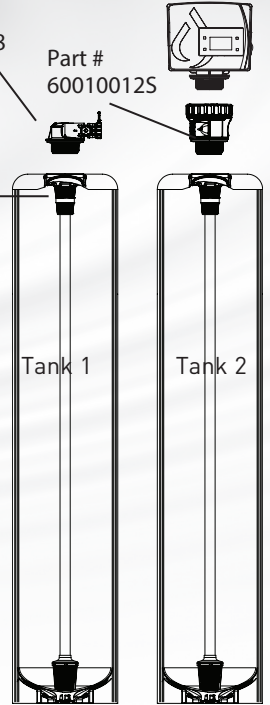

Bypass - Part # 60010004

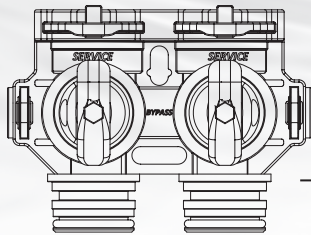

Model	Mineral Tank 1 Size	Tank 1 Media	Tank 2 Media	Distributor#	Valve #
EV-ELT-948-1.0	9x48	NW-C12 Ultra-Refiner	NW-UHC 100 Hydro-Conditioning	50010006	10010044
EV-ELT-1054-1.0	10x54	NW-C12 Ultra-Refiner	NW-UHC 100 Hydro-Conditioning	50010005	10010044
EV-ELT-1252-1.0	12x52	NW-C12 Ultra-Refiner	NW-UHC 100 Hydro-Conditioning	50010005	10010044
EV-ELT-1354-1.0	13x52	NW-C12 Ultra-Refiner	NW-UHC 100 Hydro-Conditioning	50010005	10010044

TANK ONE CARBON

Model	Mineral Tank Size	Tank # (Natural Color)	Distributor#	Valve #	Media Bed #
Refiner Upflow (Single Tank)					
EV-ELT-948-1.0	9x48	25010025	50010005	10010044	95401
EV-ELT-1054-1.0	10x54	25010034	50010005	10010044	95401
EV-ELT-1252-1.0	12x52	25010049	50010005	10010044	95402
EV-ELT-1354-1.0	13x52	25010058	50010005	10010044	95403

TANK TWO RESIN

Model	Mineral Tank Size	Tank # (Natural Color)	Distributer#	Valve #	Media Bed #
Refiner Upflow (Single Tank)					
EV-ELT-948-1.0	9x48	25010025	50010005	10010044	95600
EV-ELT-1054-1.0	10x54	25010034	50010005	10010044	95601
EV-ELT-1252-1.0	12x52	25010049	50010005	10010044	95606
EV-ELT-1354-1.0	13x52	25010058	50010005	10010044	95609

O-ring Part # 60010077

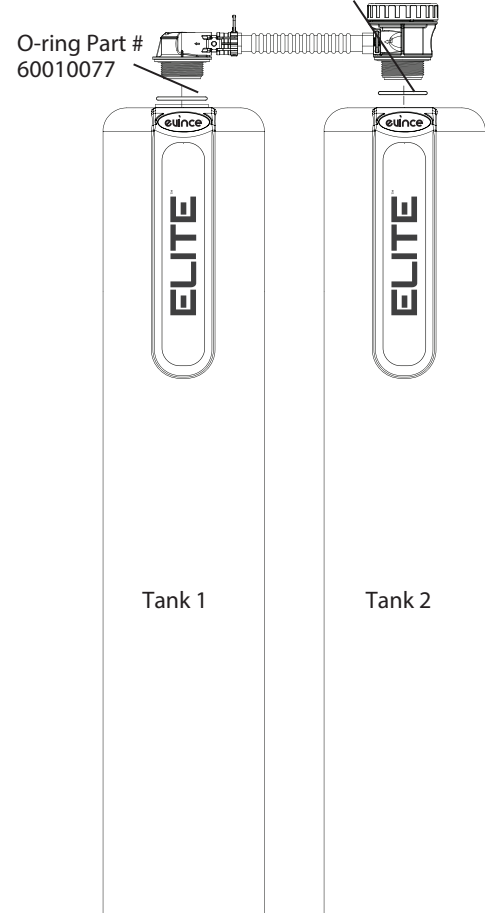

PARTS BREAKDOWN

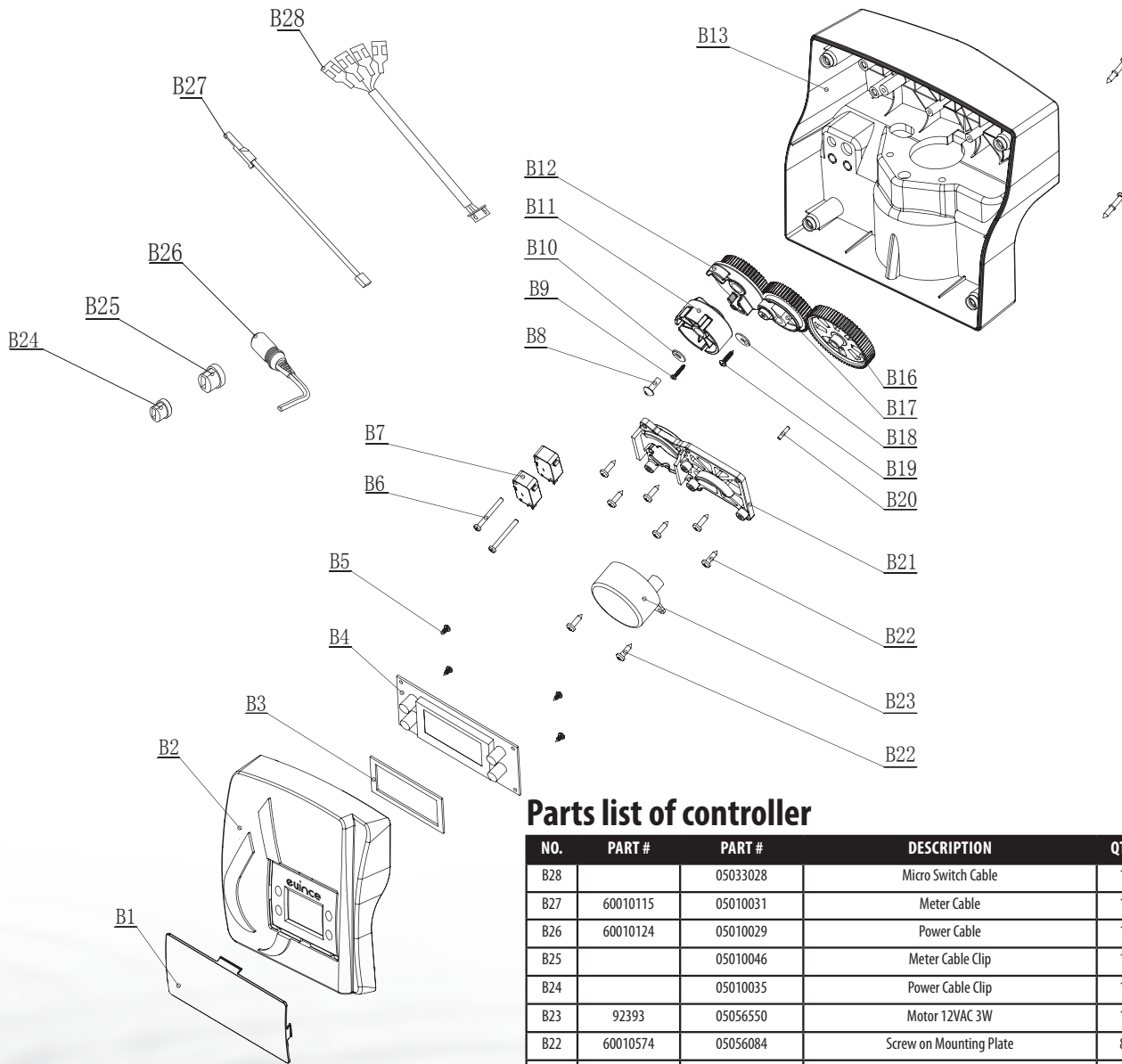

Parts list of controller

NO.	PART #	PART #	DESCRIPTION	QTY
B28		05033028	Micro Switch Cable	1
B27	60010115	05010031	Meter Cable	1
B26	60010124	05010029	Power Cable	1
B25		05010046	Meter Cable Clip	1
B24		05010035	Power Cable Clip	1
B23	92393	05056550	Motor 12VAC 3W	1
B22	60010574	05056084	Screw on Mounting Plate	8
B21		05031006	Mounting Plate	1
B20		05056098	Motor Pin	1
B19	60010099	13000426	Screw on Main Gear	1
B18	60010100	05056139	Washer on Main Gear	1
B17	92391	05031008	Main Gear	1
B16	92389	05030009	Drive Gear	1
B15		13000448	Screw on Back Cover	4
B14		13113051	Washers on Screw	4
B13		05033012B	Back Cover(White)	1
B12	92392	05031017	Brine Gear	1
B11		05033019	Locating wheel(UF)	1
B10		05056141B	Washer on Locating Wheel	1
B9		05033004	Screw 2.2×13	1
B8		05056166B	Screw on Locating Wheel	1
B7		05041011	Micro Switch	2
B6		13000332	Screws on Micro Switch	2
B5		13000401	Screws on PCB	4
B4	92388	05033008B	PCB	1
B3		05033027	PCB Absorb Shock Foam	1
B2		05033011F	Front Cover(White)	1
B1	DNR	05033007E	Controller Touch Panel(Evince®)	1

PARTS BREAKDOWN

Parts list of control valve body:

No.	Part # (Water Group)	Part # (Canature)	Description	Qty
A51	60010184	21389033	Brine Line Elbow Nut	1
A50	60010172	30020013M	Brine Line Elbow	1
A49	60010044	05056134	O-ring of Brine Line Elbow	1
A48	60010188	05031033	O-ring of BLFC Holder	1
A47	60010173	05031010M	BLFC Holder	2
A46	60010128	05056206M	BLFC(0.2GPM)(Optional)	1
A45	60010340	05033033	Brine Line Connector	1
A44	60010265	26010189	O-ring on Brine Line Connector	1
A43	60010099	13000426	Screw on Valve Bottom Connector	2
A42	60010599	07060007	Valve Bottom Connector	1
A41	60010080	26010103	Distributor O-ring	1
A40	60010598	05033021M	Central Pipe Adaptor	1
A39	60010597	26010038	O-ring of Central Pipe Adaptor	1
A38	60010077	05056063	Tank Mouth O-ring	1
A37	60010715	05033009	Screen 89 Valve	1
A36	60010595	05033020	Injector Cover	1
A35	60010341	26010101	O-ring of Injector Cover	1
A34	60010186	05031019	Big O-ring of Injector Holder	1
A33			Injector Nozzle(Optional)	1
A32	60010174	05031012M	Injector Holder	1
A31			Injector Throat(Optional)	1
A30	60010187	05031020	Small O-ring of Injector Holder	1
A29		05033010	89 Valve Body	1
A28	60010069	05056172N	Secure Clip Brine Line	1
A27	60010343	05033005B	End Plug Retainer	1
A26	60010076	05056088	Valve Body Connect Screws	2
A25	60010075	05056087	End Plug Retainer Screws	3
A24	60010574	05056084	Screw 3.5x13	1
A23	60032	05056180M	Brine Valve Injector Stem Assembly	1
A22		05033015	Spacer-89 Valve	8
A21		05033006	Seal-89 Valve	5
A20			Down Flow Piston-89 Valve	1
A19			92384 - UP PISTON ASSY	1
A18	92383 - DF PISTON ASSY		92385 - FILTER PISTON ASSY	1
A17	92384 - UP PISTON ASSY		End Plug-89 Valve	1
A16	92385 - FILTER PISTON ASSY		Piston Rod-89 Valve	1
A15			Piston Assembly-89 Valve(DF)	1
A14			DLFC(2.4GPM)(Optional)	1
A13	60095694	05040030M	DLFC Holder	1
A12	60010211	05056121	O-ring on Drain Elbow	1
A11	60010253	05040130M	Drain Elbow 3/4" NPT	1
	60010254	05040131M	Drain Elbow 1" NPT	1
A10	60010227	05040018M	Secure Clip of Drain Line	1
A9	60010585	05005636M	Big O-ring of Adaptor Coupling	2
A8			Adaptor Coupling	2
A7			Small O-ring of Adaptor Coupling	2
A6	92387	05033022M	Adaptor Secure Clip	2
A5	60010589	05033013	89 Valve Connector	1
A4	60010596	05056508	Screws of Valve Connector	8
A3	60010238	02170055	Impeller Assembly	1
A2		05010019	Bush	2
A1	60010587	05010077	Impeller Holder	1

Seal and Spacer Kit 92382

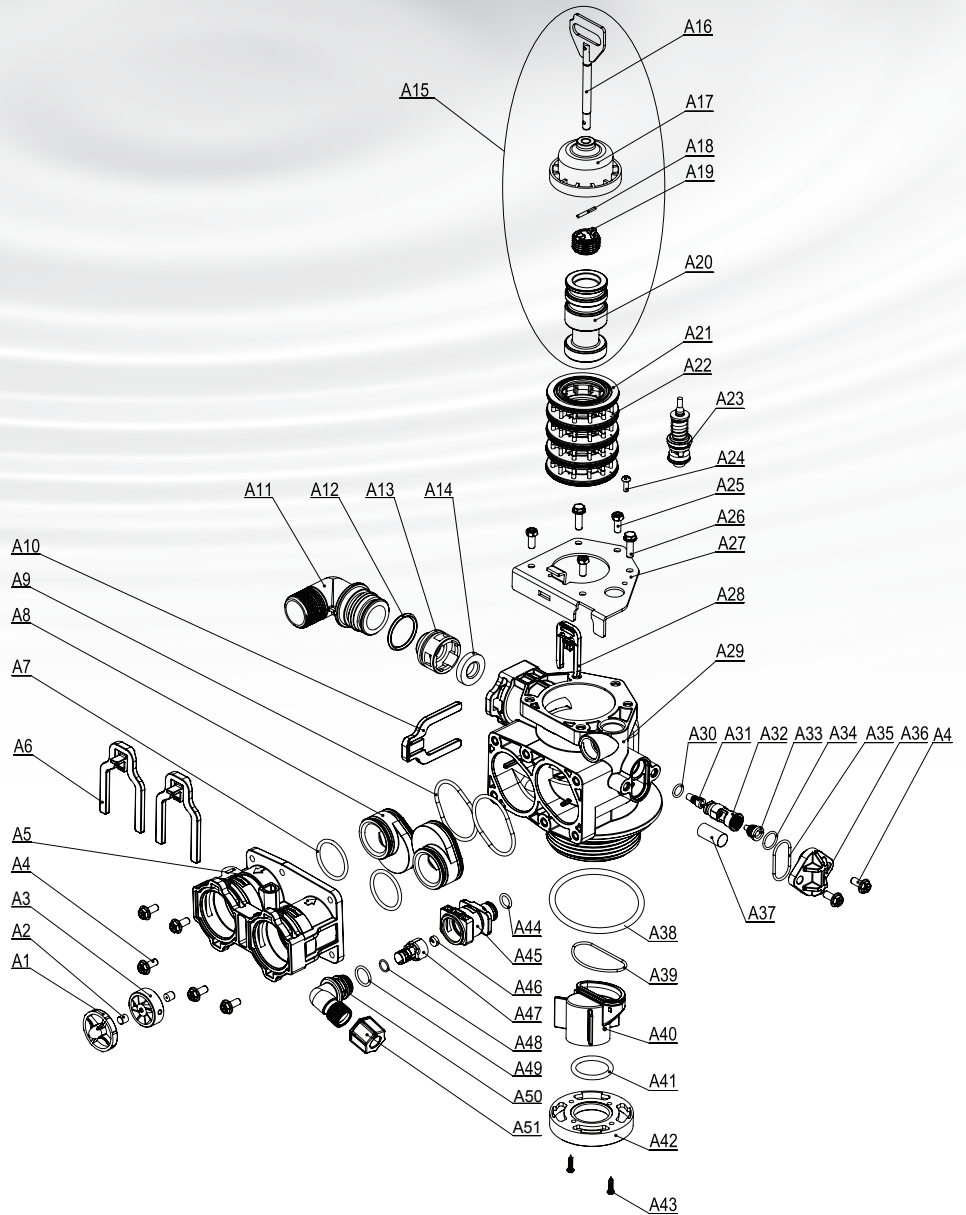

Item #s For All Injector Assemblies and Brine Line and Drain Line Washers

Part #	Part Description	Part #	Part Description
60010110	BLFC BUTTON #2 0.3GPM A32	60010613	INJECTOR SET #3 YELLOW THROAT
60010082*	BLFC BUTTON #2 0.7GPM A32	60010614	NOZZLE #3 YELLOW THROAT
60010128	BLFC BUTTON 0.2GPM	60010685	INJECTOR SET #4 GREEN THROAT
60010601	INJECTOR SET #0000 BLACK THROAT	60010686	NOZZLE #4 GREEN THROAT
60010602	NOZZLE #0000 BLACK THROAT	12052	1.4 GPM DLFC WASHER
60010603	INJECTOR SET #000 GREY THROAT	12053	2.0 GPM DLFC WASHER
60010604	NOZZLE #000 GREY THROAT	60010140	#45 5.0GPM
60010605	INJECTOR SET #00 VIOLET THROAT	60010142	#75 7.0 GPM
60010606	NOZZLE #00 VIOLET THROAT	60010143	#1 8.0 GPM
60010607	INJECTOR SET #0 RED THROAT	60010144	#2 11.0 GPM
60010608	NOZZLE #0 RED THROAT	60010145	#3 14.0 GPM
60010609*	INJECTOR SET #1 WHITE THROAT	60010146	#4 17.0 GPM
60010610*	NOZZLE #1 WHITE THROAT	60010147	#5 21.0 GPM
60010611	INJECTOR SET #2 BLUE THROAT	60010148	#6 24.0 GPM
60010612	NOZZLE #2 BLUE THROAT		

* Default

TROUBLE SHOOTING GUIDE

PROBLEM	POSSIBLE SOLUTIONS
<p>1. CONDITIONER DELIVERS HARD WATER</p> <ul style="list-style-type: none"> A. Bypass valve is open B. No sodium in brine tank C. Injector or screen plugged D. Insufficient water flowing into brine tank E. Hot water tank hardness F. Leak at distributor tube G. Internal valve leak H. Flow meter jammed I. Flow meter cable disconnected or not plugged into meter cap J. Improper programming 	<ul style="list-style-type: none"> A. Close bypass valve B. Add sodium to brine tank and maintain sodium level above water level C. Replace injectors and screen D. Check brine tank fill time and clean brine line flow tank control if plugged E. Make sure distributor tube is not cracked. Check O ring and tube pilot F. Make sure distributor tube is not cracked. Check O ring and tube pilot G. Replace seals and spacers and/or piston H. Remove obstruction from flow meter I. Check meter cable connection to timer and meter cap J. Reprogram the control to the proper regeneration type, inlet water hardness, capacity or flow meter size.
<p>2. CONDITIONER FAILS TO REGENERATE</p> <ul style="list-style-type: none"> A. Electrical service to unit has been interrupted B. Timer is not operating properly C. Defective valve drive motor D. Improper programming 	<ul style="list-style-type: none"> A. Assure permanent electrical service (check fuse, plug, chain or switch) B. Replace timer C. Replace drive motor D. Check programming and reset as needed
<p>3. UNIT USES TOO MUCH SODIUM</p> <ul style="list-style-type: none"> A. Improper sodium setting B. Excessive water in brine tank C. Improper programming 	<ul style="list-style-type: none"> A. Check sodium usage and sodium setting B. See #7 C. Check programming and reset as needed
<p>4. LOSS OF WATER PRESSURE</p> <ul style="list-style-type: none"> A. Iron build-up in line to water conditioner B. Iron build-up in water conditioner C. Inlet of control plugged due to foreign material broken loose from pipes by recent work done on plumbing system. 	<ul style="list-style-type: none"> A. Clean line to water conditioner B. Clean control and add resin cleaner to resin bed. Increase frequency of regeneration C. Remove piston and clean control
<p>5. LOSS OF MEDIA THROUGH DRAIN LINE</p> <ul style="list-style-type: none"> A. Air in water system B. Drain line flow control is too large 	<ul style="list-style-type: none"> A. Assure that well system has proper air eliminator control. Check for dry well condition. B. Ensure drain line flow control is sized
<p>6. IRON IN CONDITIONED WATER</p> <ul style="list-style-type: none"> A. Fouled media bed B. Iron content exceeds recommended parameters 	<ul style="list-style-type: none"> A. Check backwash, brine draw and brine tank fill. Increase frequency of regeneration. Increase backwash time. B. Add iron removal filter system
<p>7. EXCESSIVE WATER IN BRINE TANK</p> <ul style="list-style-type: none"> A. Plugged drain line flow control B. Brine valve failure C. Improper programming 	<ul style="list-style-type: none"> A. Clean flow control B. Replace brine valve C. Check programming and reset as needed
<p>8. SODIUM WATER IN SERVICE LINE</p> <ul style="list-style-type: none"> A. Plugged injector system B. Timer not operating properly C. Foreign material in brine valve D. Foreign material in brine line flow control E. Low water pressure F. Improper programming 	<ul style="list-style-type: none"> A. Clean injector and replace screen B. Replace timer C. Clean or replace brine valve D. Clean brine line flow control E. Raise water pressure F. Check programming and reset as needed
<p>9. CONDITIONER FAILS TO DRAW BRINE</p> <ul style="list-style-type: none"> A. Drain line flow control is plugged B. Injector is plugged C. Injector screen is plugged D. Line pressure is too low E. Internal control leak F. Improper programming G. Timer not operating properly 	<ul style="list-style-type: none"> A. Clean drain line flow control B. Clean or replace injectors C. Replace screen D. Increase line pressure (line pressure must be at least 20 psi at all times) E. Change seals and spacers and/or piston assembly F. Check programming and reset as needed G. Replace timer
<p>10. CONTROL CYCLES CONTINUOUSLY</p> <ul style="list-style-type: none"> A. Timer not operating properly B. Faulty microswitches and/or harness C. Faulty cycle cam operation 	<ul style="list-style-type: none"> A. Replace timer B. Replace faulty microswitch or harness C. Replace cycle cam or reinstall

TROUBLE SHOOTING GUIDE

Problem	Possible Solutions
11. DRAIN FLOWS CONTINUOUSLY A. Foreign material in control B. Internal control leak C. Control valve jammed in brine or backwash position D. Timer motor stopped or jammed teeth E. Timer not operating properly	A. Remove piston assembly and inspect bore. Remove foreign material and check control in various regeneration positions B. Replace seals and/or piston assembly C. Replace piston and seals and spacers D. Replace timer motor and check all gears for missing teeth E. Replace timer
12. (Error Code) (Error E1) - Electrical Trouble Shooting: Issue1: When the controller is plugged, the buzzer beeps and the screen displays "System Error E1" Cause: The wire of micro switch is not plugged or loose.	Check the micro switch and connect the wire well.
13. (Error Code) (Error E1) - Electrical Trouble Shooting: Issue 2: The buzzer beeps and the screen displays "System Maintaining E1" Cause: The wire of micro switch is not plugged or loose..	Check the micro switch and connect the wire.
14. (Error Code) (Error E2) - Electrical Trouble Shooting: Issue: The buzzer beeps and the screen displays "System Error E2" Cause: The motor can not find its right position, micro switch or motor malfunction, automatic circuit protection action.	Check the current of micro switch and motor.
15. (Error Code) (Error E2) - Electrical Trouble Shooting: Issue 2: The buzzer beeps and the screen displayed " System Maintaining E2" Cause: The motor can not find its right position.	Replace Motor or PCB.

MASTER PROGRAMMING GUIDE

Below is how the settings are set at factory:

MASTER PROGRAMMING - 89 DYNAMIC REGENERATION Master Programming (V1.5)												
PRESS '+' AND '-' FOR 8 SECONDS								PRESS MENU KEY AND SCROLL TO 'MAIN MENU'. THEN PRESS 'SET' TILL IT BEEPS. SCROLL TO ADVANCED MENU				
MODELS	LANGUAGE	REGION	VALVE	METER RATIO	SODIUM VS EFFICIENCY	AUTO CALCUL	Cycle Delay	MEDIA VOLUME	REFILL RATE	REGEN MODE	BW/RINSE OVERRIDE	EMERGENCY REGEN.
EV-ELT-948-1.0	ENGLISH	US GALLONS	DYNAMIC	Turbine L	DEFAULT	ON	DEFAULT	1.0CF	0.2	METER DELAY	10	OFF
EV-ELT-1054-1.0	ENGLISH	US GALLONS	DYNAMIC	Turbine L	DEFAULT	ON	DEFAULT	1.5CF	0.2	METER DELAY	10	OFF
EV-ELT-1252-1.0	ENGLISH	US GALLONS	DYNAMIC	Turbine L	DEFAULT	ON	DEFAULT	2.0CF	0.2	METER DELAY	10	OFF
EV-ELT-1354-1.0	ENGLISH	US GALLONS	DYNAMIC	Turbine L	DEFAULT	ON	DEFAULT	2.5CF	0.2	METER DELAY	10	OFF

MASTER PROGRAMMING GUIDE (CONTINUED)

MASTER PROGRAMMING - DYNAMIC Master Programming (V1.5)										
PRESS MENU KEY AND SCROLL TO 'MAIN MENU'. THEN PRESS 'SET' TILL IT BEEPS. SCROLL TO ADVANCED MENU										
BRINE RINSE	BACK WASH	RINSE	BRINE REFILL	AUXILIARY OUTPUT	SERVICE SETTINGS	BACKLIGHT SETTINGS	HISTORY VALUES	SODIUM REMINDER - SODIUM USAGE	ALARM ON TIME	SODIUM QUANTITY
DEFAULT	DEFAULT	DEFAULT	DEFAULT	DONT TOUCH	OFF	Energy Save	Reset history	DEFAULT	5:00PM-7:00PM	80 lbs

MASTER PROGRAMMING - DYNAMIC Master Programming (V1.5)									
PRESS MENU KEY AND SCROLL TO 'MAIN MENU'. THEN PRESS 'SET' TILL IT BEEPS					VALVE SETTINGS				
REGEN TIME	SYSTEM CAPACITY	SODIUM MODE SETTING	BRINE PRE-FILL SET	PREFILL	Injector	Injector Color	BLFC Washer	DLFC Washer	DLFC Washer Code
2:00AM	DEFAULT	STANDARD	ON	70%	#0000	Black	0.2 GPM	2.0	#2
2:00AM	DEFAULT	STANDARD	ON	70%	#0000	Black	0.2 GPM	2.4	1S
2:00AM	DEFAULT	STANDARD	ON	70%	#00	Purple	0.2 GPM	3.5	2S
2:00AM	DEFAULT	STANDARD	ON	70%	#00	Purple	0.2 GPM	4.0	3S

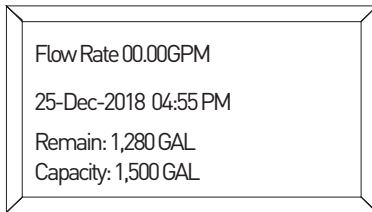



The controller will show the following on the screen - Time, Date and number of Days Remaining for Regeneration:



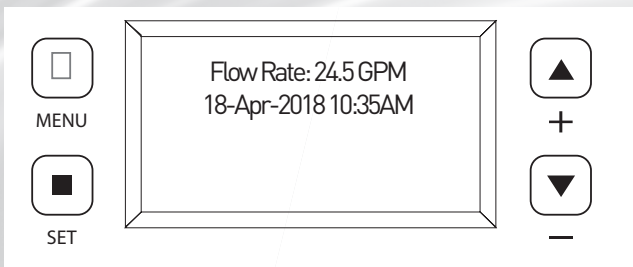
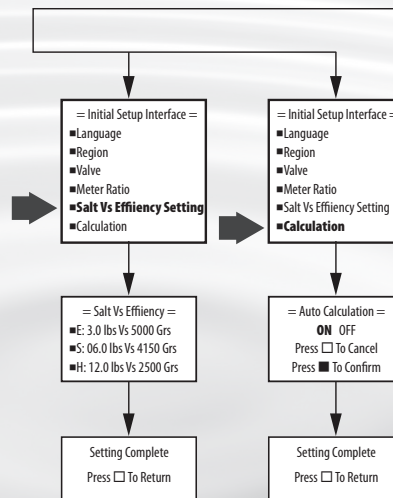
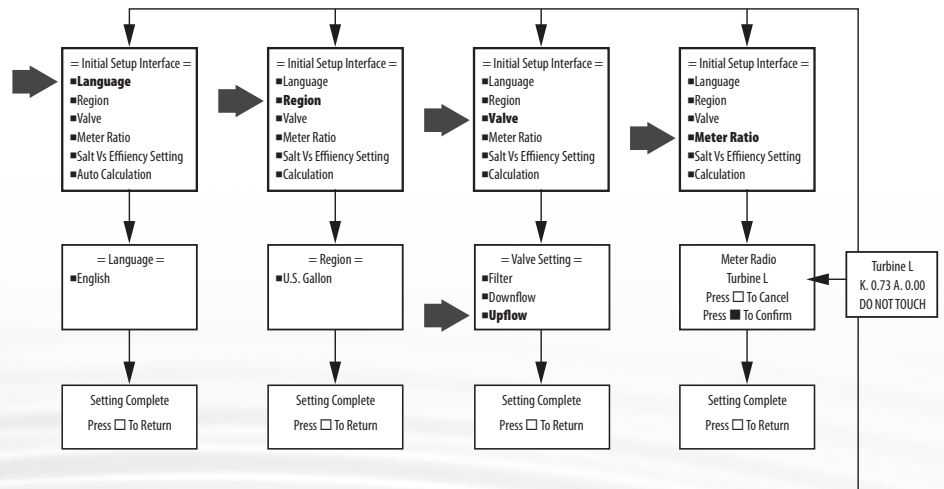





How to set Master Programming (Authorized Dealer Only)

Press and for 8 seconds. Press **SET** to select and **MENU** to go back



ADVANCED MENU DYNAMIC

PRESS "MENU" KEY  AND SCROLL TO "MAIN MENU". THEN PRESS "SET"  TILL IT BEEPS. SCROLL TO ADVANCED MENU

PRESS "MENU" KEY . PRESS - TO ADVANCE TO ADVANCED MENU. PRESS AND HOLD "SET"  5 SECONDS OR UNTIL YOU HEAR A BEEP. PRESS  OR  TO CHOOSE MENU OPTION. PRESS "SET"  TO ENTER. PRESS  OR  TO CHANGE OPTION. PRESS "SET"  TO ACCEPT.

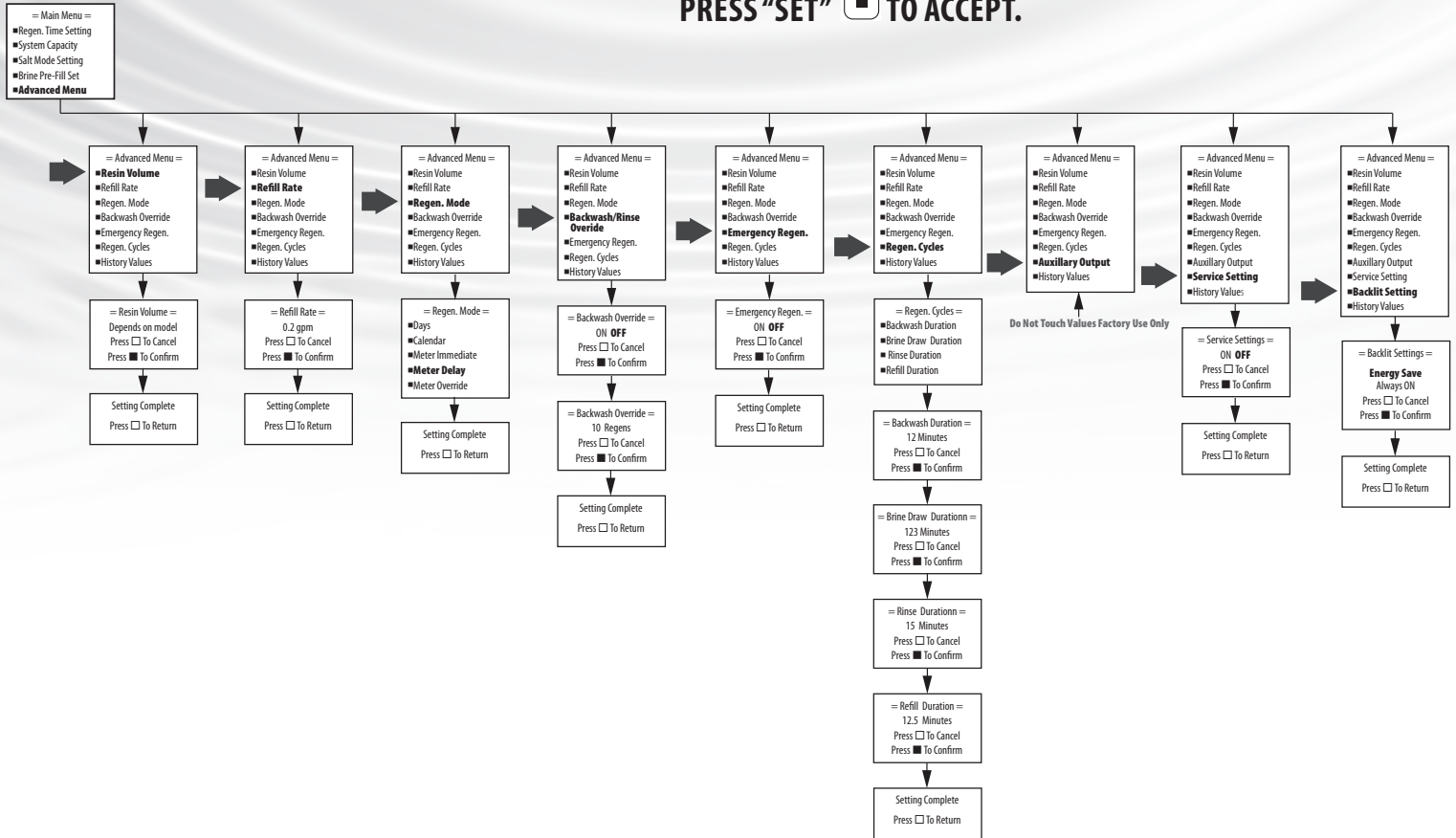



ADVANCED MENU DYNAMIC

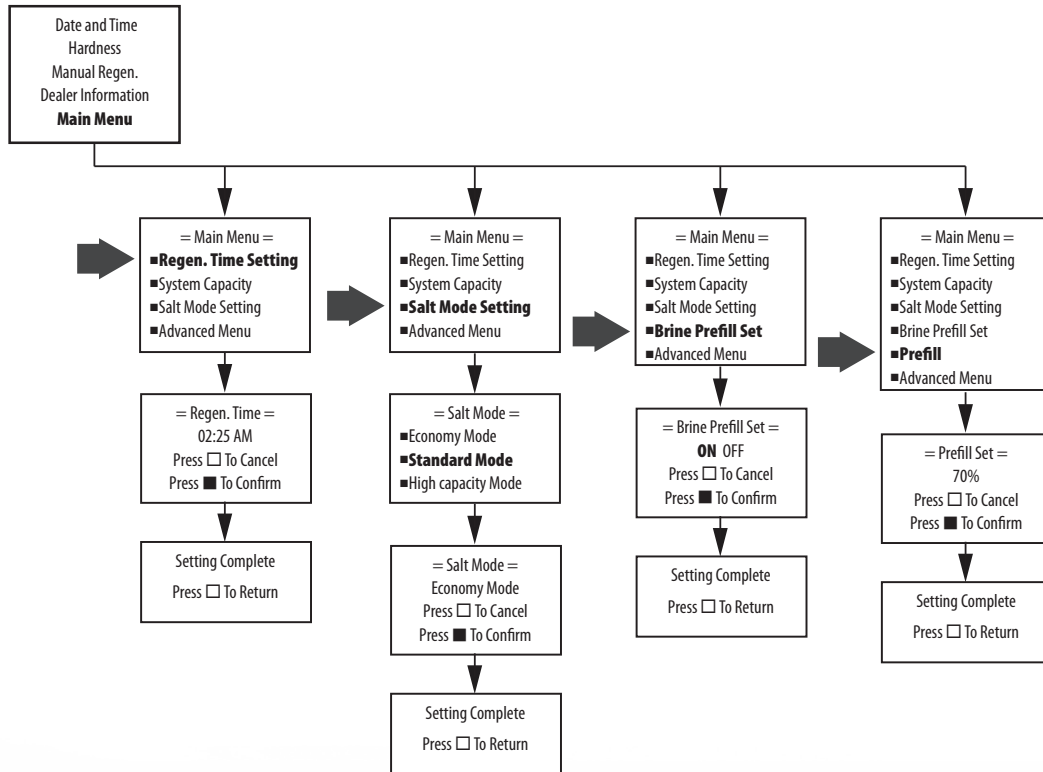





Press "MENU" key . Press - to advance to Advanced Menu. Press and hold "SET" 5 seconds or until you hear a beep. Press or to choose menu option. Press "SET" to enter. Press or to change option. Press "SET" to accept.



HOW TO SET DATE AND TIME, MANUAL REGENERATION AND DEALER INFORMATION

PRESS "MENU" KEY  AND SCROLL TO "MAIN MENU". THEN PRESS "SET"  TILL IT BEEPS.

PRESS "MENU" KEY  AND SCROLL TO "MAIN MENU". THEN PRESS "SET"  TILL IT BEEPS.

Press "MENU" key 
 Press  or  to change menu option.
 Press "SET"  to enter.
 Press  or  to change value.
 Press "SET"  to accept.

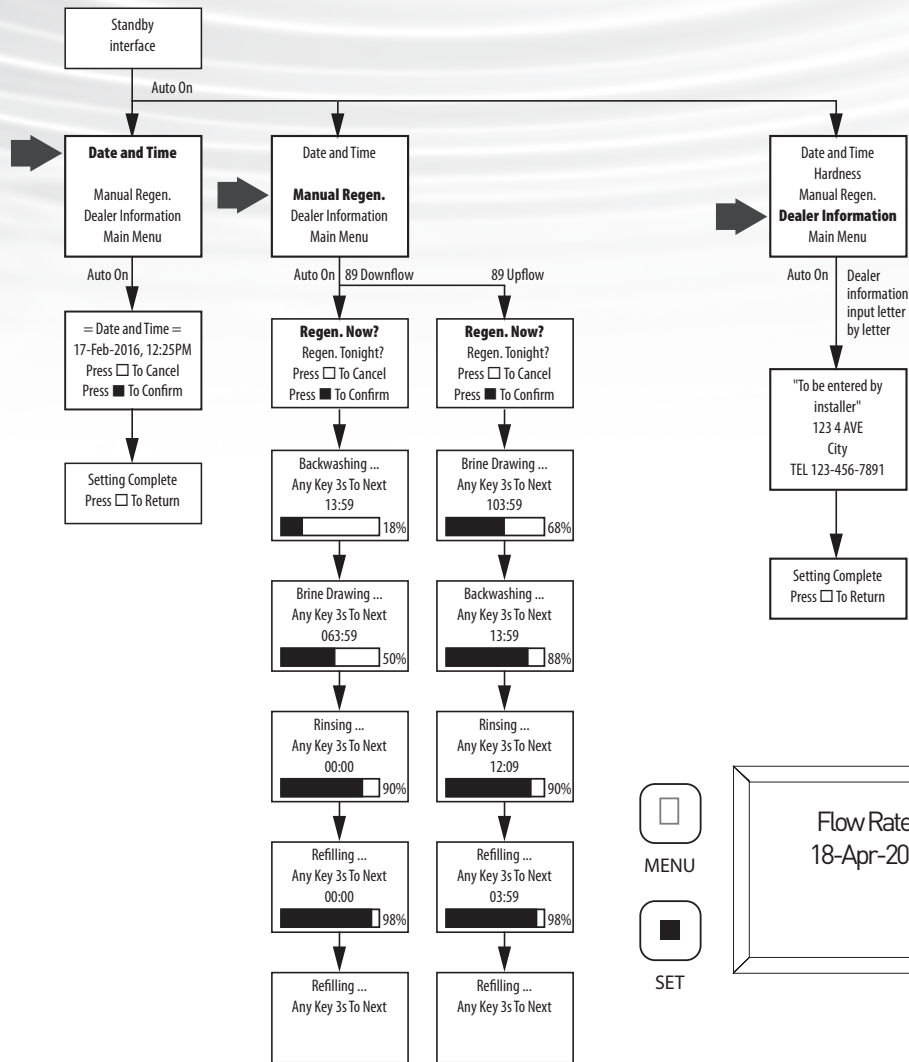

MENU



SET

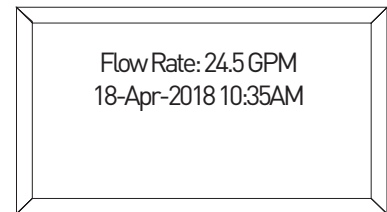

+



-

DATE AND TIME

Time of day is for normal operation of system and the scheduling of the regeneration time. The date is used in a diagnostic function to track the last time the system-generated.

HARDNESS

This value is the maximum compensated water hardness in grains per gallon of the raw water supply. It is used to calculate the system capacity. If Ferrous Iron is present add 4 gpg for every 1 ppm of Ferrous Iron.

MANUAL REGENERATION

To start an immediate regeneration select the Manual Regen option. This setting determines the time of day to perform a scheduled regeneration.

DEALER INFORMATION

This is optional. Dealer information can be added.





Evince® warrants that your new water conditioner is built of quality material and workmanship. When properly installed and maintained, it will give years of trouble free service.

Ten Year Complete Parts Warranty

Evince® will replace any part which fails within 120 months from date of manufacture, as indicated by the serial number, provided the failure is due to manufacturer defect. The only exception shall be when proof of purchase or installation is provided and then the warranty period shall be from the date thereof.

Life Time Warranty on Mineral Tanks and Brine Tanks

Evince® will provide a replacement mineral tank or brine tank to any original equipment purchaser in possession of a tank that fails provided that the water conditioner is at all times operated in accordance with specifications and not subject to freezing or vacuum.

General Conditions

Damage to any part of this water conditioner or filter as a result of misuse, misapplication, neglect, alteration, accident, installation or operation contrary to our printed instructions, damage to ion exchange resin and seals caused by chlorine / chloramines in the water supply, or damage caused by any force of nature is not covered in this warranty. We will repair or replace defective parts if our warranty department determines it to be defective under the terms of this warranty. **Evince®** assumes no responsibility for consequential damage, labor or expense incurred as a result of a defect or failure.

Evince Water Group Inc.®

Direct Phone Number: 951.336.0966

1641 Commerce St.

Corona, CA 92878